

Abstract

This paper presents ongoing research and current results on the development of a product for cursor control which utilizes eye blink for computer input. Various techniques for head and eye movement detection already exist for cursor control for which they use image processing. The paper discusses about the IR (infra-red) Transmitter & Receiver technology which has been used to sense eye signals with which the mouse cursor can be made to click. By using this technology and by implementing certain programs in visual basic and C, we can also play songs and display certain messages on the screen as the user wants to. These experiments are directed towards creation of a product which will be beneficial for people with disabilities, with little to no cost involved.

Keywords: Human computer interaction (HCI), IR (infra-red) Transmitter & Receiver, Eye blink, Cursor control

1. Introduction

There exists a significant population who, due to disease or injury, have their limbs totally paralysed but have normal or near-normal head movement. In cases where the person has even a slight degree of voluntary movement (e.g., eye blink), it is possible to use that movement as a switch for controlling a computer. It is also possible to employ programming in visual basic or C to display messages and play songs in media player using eye blink. Nowadays HCI is a very known field which deals with the study, planning and design of the interaction between people (users) and computers. Interaction between users and computers occurs at the user interface, which may include software, hardware or both. HCI aims to design systems that will make computers more receptive to user's needs [1]. Scientists from the US firm Cyber kinetics have developed a brain implant Brain Gate that allows people to control electronic devices by thought alone. The device was successfully implanted in 25-years old Matthew Nagle, who is paralysed from the neck down. The device enabled him to play computer games and to open and close the hand on a prosthetic limb just by thinking about them. Some research work has already been carried out on the technology electro-oculography, which senses eye signals with which the mouse cursor can be controlled. The signals captured using sensors, are first amplified, then noise is removed

*Department of Computer Science & Engineering, Lingaya's University, Faridabad, India

**Department of Computer Science & Engineering, Lingaya's University, Faridabad, India

and then digitized, before being transferred to PC for software interfacing. [2]. there is also use of the P300 event related potential as a control signal in a computer interface for locked-in patients. These experiments are directed toward development of a device which uses the occurrence of a P300 to control motion of a cursor on a computer screen. Simultaneous target-detection tasks are presented in four compass positions (N, E, S, W) on a computer screen. The subject is instructed to detect targets in one of the positions corresponding to the intended direction of cursor movement [3]. The Brain Gate system uses neuromotor prosthesis, an electronic chip that is inserted into the motor cortex of the brain. The 100 electrodes penetrate into the surface of the brain and pick up the electrical activity of the cells. The resulting signals are interpreted by a computer, which makes it possible to control objects such as artificial limbs, computer cursors or wheelchairs. But it is not possible for everyone to go for such expensive technologies. Because of its robustness, it is believed that an evoked infra red signal, may serve as a good candidate for a PLL controlled computer interface [4]. There was another development in this field that would utilize electric potentials generated by the human eye in order to control the mouse cursor on the screen. Creating a fully working FPGA based mouse emulator with bidirectional PS/2 communication support, as well as a circuit for filtering, amplifying, and then isolating signals from an electro-oculogram were the two major blocks of design required [5]. In the present experiment the possibility of using a goggle fitted with Infrared transmitter and receiver, to convey the user's message of cursor blinking will be explored. The circuit will be fitted in the goggle manually by hit and trial method. The transmitter-receiver circuit will preferably be 38 kHz frequency based phase lock loop controlled. This circuit will be interfaced with the inport of parallel port of computer using suitable amplifier. The flickering of eye gives an obstruction to the receiver (photo diode). The open eye gives no more code indication & every time when someone close the eye for a moment it gives "dit" (dot) and the one second closing of eye gives a "dat" (dash) & "dit" (dot) indication. The computer connected to this circuit using parallel port receives all the input morse code signals and the software written in C decodes the code accordingly and make the message already stored in system.

2. Algorithm

For the sake of experimentation ten general messages were stored in a pc which a paralytic patient may want to convey to other persons. A delay element was also introduced which will distinguish between voluntary and involuntary eye blink. The value at the inport of pc was stored in a variable. This value was then matched with a particular value which will be at the inport when the LED glows. If both the values happen to be the same then the message is printed on the screen. Now out of the ten messages a particular message selection also depends on eye blink. A variable was taken for this purpose which was initialized with value zero. After matching the inport value a loop was run which also incremented this variable's value by one. Once the value reached ten it was again set to zero and the loop resumed. The loop's execution depends on eye blink i.e. for one blink the loop is executed once.

3. Implementation

In assembling the whole circuit many number of possibilities were tried but the actual circuit must be optimal in performance.

A. Sensing Eye Signals

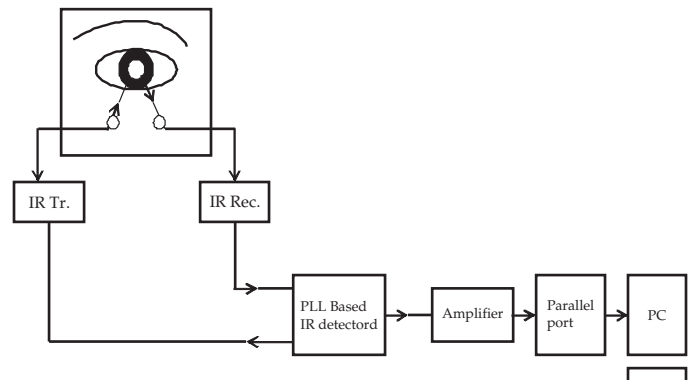

Fig. 1: Working Principle

As soon as the IR light beam transmitted is obstructed, a momentary pulse actuates the relay output (or LED). The IR transmitter is simple series connected resistor network from battery. A relay is an electrical switch that opens and closes under control of another electrical circuit. In the original form, the switch is operated by an electromagnet to open or close one or many sets of contacts. To achieve electrical isolation, a light-emitting diode (LED) is used with a photo transistor. Relays can be used to detect and isolate faults on transmission and distribution lines by opening and closing circuit breakers (protection relay).

B. Timer Operation

The 555 integrated circuit is an extremely versatile timer that can be used in many different applications. This IC is a monolithic timing circuit that is a highly stable controller capable of producing accurate time delays or oscillations. Additional terminals are provided for triggering or resetting if desired in the time delay mode of resistance and a capacitor. For a stable operation as an oscillator, the free running frequency and the duty cycle are both accurately controlled with two external resistors and one capacitor. The circuit may be triggered and reset on falling waveforms, and the output structure can source or sink up to 200ma or drive TTL Circuits.

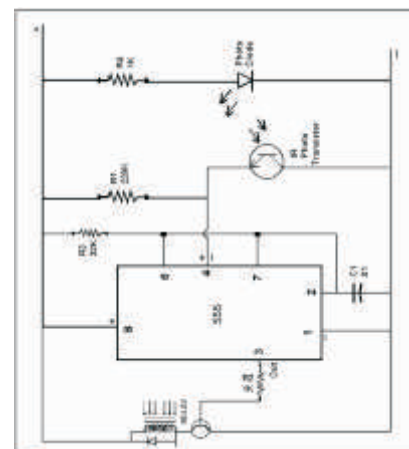

Fig. 2: 555 Integrated Circuit [6]

The 555 timer offers timing from microseconds through hours and operates in both a stable and monostable modes. It has an adjustable duty cycle, and the output can drive TTL devices. Its output can operate in normally on and normally off modes and the IC offers a frequency stability of 0.005% per degrees centigrade. The timing capacitor connected to pin 2 and ground can varied as per requirement. In this IR detector and transmitter circuit, IC 555 is working under a stable mode. The pin 4 i.e. reset pin is when grounded via IR receiver the pin 3 output is low. Applications for the 555 chip include precision timing, pulse generation, pulse width modulation, pulse position modulation, sequential timing, and missing pulse detection.

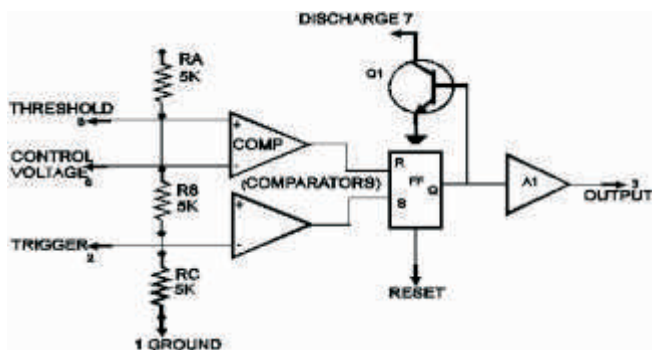

Fig. 3: Actual Circuit

C. IC-555 Astable Operations

If the circuit is connected as shown in figure (pins 2 and 6 connected). It will trigger itself and free run as a multivibrator. The external capacitor charges through Ra and Rb and discharges through Rb only. Thus, the duty cycle may be precisely set by the ratio of these two resistors. In this mode of operation the capacitor charges and discharges between 1/3 Vcc and 2/3 Vcc. As in the triggered mode, the charge and discharges times, and therefore, the frequency are independent of the supply voltage. Figure shows the actual waveforms generated in this mode of operation. Some of the equations are:-[6]

The charge time (output high) is given by:
 $t_1 = 0.685 (Ra + Rb) C$

And the discharge time (output low) by:
 $t_2 = 0.685 (Rb) C$

Thus, the total period is given by:
 $T = t_1 + t_2 = 0.685 (Ra + 2Rb) C$

The frequency of oscillation is then:
 $f = \frac{1.46}{(Ra + 2Rb) C}$

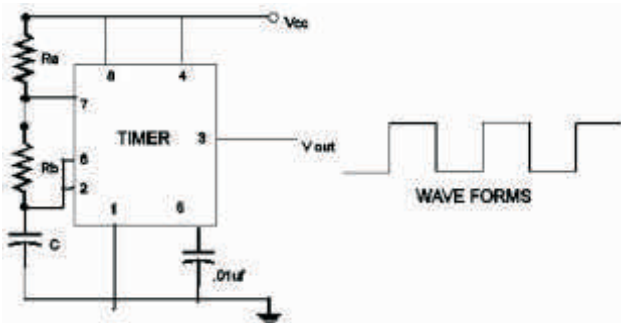

Fig. 4: Actual Waveform Generated in Operation [6]

D. IC-555 Monostable Opertaions

In the monostable mode of operation, the timer functions as a one shot. Referring to figure the external capacitor is initially held discharged by a transistor inside the timer. Upon applications of a negative trigger pulse to pin 2, the flip-flop is set, which releases the short circuit across the external capacitor and drives the output high. The voltage across the capacitor increases exponentially with the time constant.

$t = Ra C$

When the voltage across the capacitor equals 2/3 Vcc. The comparator resets the flip-flop, which, in turn, discharges the capacitor rapidly and drives the output to its low state. Figure shows the actual waveforms generated in this mode of operation. The circuit triggers on a negative going input signal when the level reaches 1/3 Vcc. Once triggered, the circuit will remain in this state until the set time is elapsed, even if it is triggered again during this interval. The time that the output is in the high state is given by: $t = 1.1 Ra C$

Applying a negative pulse to the reset terminal (pin 4) during the timing cycle discharges the external capacitor and causes the cycle to start over again. The timing cycle will now commence on the positive edge of the reset pulse. During the time the reset pulse is applied, the output is driven to its low state.

4. System Requirement to Be Meet

A. Hardware Needed

The hardware implementation was a infrared receiver transmitter fitted into a goggle using phase lock loop with a maintained frequency of 38 KHZ internally. In this IR detector and transmitter circuit the IC 555 is working under MONOSTABLE mode. Relay was used to detect the obstruction of IR light beam being transmitted, after which a momentary pulse actuated the relay output. To achieve electrical isolation, a light-emitting diode (LED) was used with a photo transistor

B. Software Needed

The software implementation was based on interfacing of the infrared receiver transmitter circuit with the import of parallel port of computer using suitable amplifier. The flickering of eye gives an obstruction to the receiver (photo diode). The open eye gives no more code indication & every time when someone close the eye for a moment it gives "dit" (dot) and the one second closing of eye gives a "dat" (dash) & "dit" (dot) indication. The computer connected to this circuit using parallel port receives all the input morse code signals and the software written in C or visual basic decodes the code accordingly and displays the message already stored in system.

When blink occurs the LED turns off. The software can play songs in media player and also change songs accordingly as the blink occurs

5. Conculsion

Overall, the IR circuit used in conjunction with the software application showed that eye blink can be used to move the cursor, play songs and generate text on a screen. The songs and messages have to be already stored in the computer which could

be played and changed according to the eye blink. One of the problems faced was the miniature jerk-like movements, or micro saccades, that the eye constantly makes. If the pupil movements were transmitted to the monitor without first being filtered, the pointer would dash around all over the monitor. The software must first suppress these micro saccades by means of a filter function, then determine the main direction of movement. Another issue was that the elements must not be too small, since the mouse cannot be controlled as accurately with the eyes as it can with the hand. Another issue was widescreen viewing. At the extremes of the screen there was not enough eye movement to over the cursor in that direction again. The key is to limit the viewing window to the centre of the screen

This technique can be used for general computer use and is relatively easier to setup. A very little cost is incurred and it uses only eye blinks.

Blinking must be controlled (not too slow) to prevent a down signal from being identified. Also the eyes can tire quickly. Larger icons must be used to click upon. This is due to eye motion slow timing. This forces the screen to be larger with large text and symbol icons (about ½ inches square)

6. Future Directions

Human Computer Interfaces have an enormous scope in near future. There are four aspects as far as future enhancements are concerned.

Make a sophisticated product that can be implemented in fighter jets. Pilot just has to point the target with the eyes and press the trigger when target becomes under the range. It will be highly appreciated since the eye movement is more fast and accurate than just the hand movement.

7. References

1. *human computer interface*, Wikipedia, http://en.wikipedia.org/wiki/Human_computer_interaction.
2. Arslan Qamar Malik, Jehanzeb Ahmad, *Retina Based Mouse Control (RBMC)*.
3. James B. Polikoff, H. Timothy Bunnell, & Winslow J. Borkowski Jr., *Toward a P300-based Computer Interface*, Applied Science and Engineering Laboratories, Alfred I. Dupont Institute.
4. Grant G. Connell, *Cursor Control Using EEG Signals from Eye Movement Potentials*.
5. Jayendra Kumar, Dr. S.N.Singh, Saktiswarup Satapathy, Somu Gorai, *Development of Software for Human Eye Controlled FPGA based Hand Free Mouse*, International Journal of Recent Trends in Engineering, Vol 2, No. 8, November 2009.
6. 555 timer IC, From Wikipedia, the free encyclopedia, http://en.wikipedia.org/wiki/555_timer_IC.