

Improved Lifespan and Attenuation free Network Coverage of Wireless Passive Sensor Networks (WPSN)

Anand Nayyar*

Abstract

System lifetime of wireless sensor networks (WSN) is inversely proportional to the energy consumed by critically energy-constrained sensor nodes during RF transmission. In that regard, modulated backscattering (MB) is a promising design choice, in which sensor nodes send their data just by switching their antenna impedance and reflecting the incident signal coming from an RF source. Hence, wireless passive sensor networks (WPSN) designed to operate using MB do not have the lifetime constraints of conventional WSN. However, the communication performance of WPSN is directly related to the RF coverage provided over the field the passive sensor nodes are deployed. In this letter, RF communication coverage in WPSN is analytically investigated. The required number of RF sources to obtain interference-free communication connectivity with the WPSN nodes is determined and analyzed in terms of output power and the transmission frequency of RF sources, network size, RF source and WPSN node characteristics.

Keywords: Wireless Sensor Networks, Wireless Passive Sensor Networks, modulated backscattering, Network Coverage.

1. Introduction

Wireless sensor networks (WSN) are, in general, composed of low-cost, low-power sensor nodes which can only be equipped with a limited power source, i.e., a battery [1]. Sensor nodes consume most of the stored power during RF transmission. At this point, modulated backscattering (MB) [2] is a promising communication technique leading to a new sensor network paradigm, Wireless Passive Sensor Networks (WPSN). WPSN are supplied with energy by external RF power sources. With MB approach, a passive sensor node transmits its data simply by modulating the incident signal from an RF source by switching its antenna impedance. Therefore, the transmitter is basically an antenna impedance switching circuitry, and WPSN is free of the lifetime constraint of conventional WSN.

As in WSN, to meet application requirements, event characteristics must be reliably sensed and communicated via collective operation of sensor nodes to remote sink in WPSN. RF sources receive the signal reflected from sensor nodes, and they should send the gathered data to the sink without causing any interference in the network. Therefore, in order to maintain the communication connectivity and RF coverage without compromising the communication reliability due to possible

interference, it is important to carefully design the WPSN deployment, especially the number of RF sources.

The main focus of this paper is to investigate the communication coverage problem in WPSN. More specifically, minimum number of RF sources to achieve successful MB-based communication in WPSN is investigated. Furthermore, the relation between the number of RF sources that are required to obtain interference-free RF communication coverage is analyzed in terms of output power and the transmission frequency of RF sources, network size, RF source and WPSN node characteristics. The results of this paper reveal that communication coverage can be practically maintained in WPSN through careful selection of design parameters.

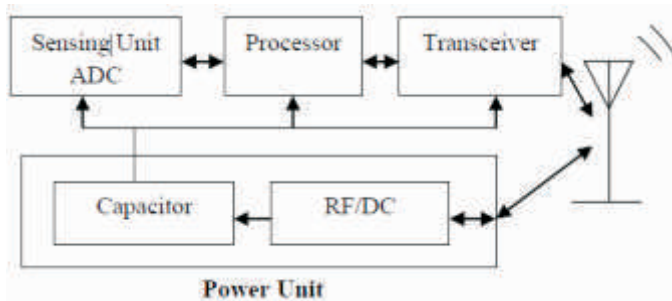

Figure 1: Structure of basic WPSN Node

2. WPSN (Wireless Passive Sensor Network)

Wireless passive sensor network proposed in this study is based on MB. The source of energy is an RF power source which is assumed to have unlimited power. The source transmits RF power to run the passive nodes, and it transmits and receives information from WPSN nodes simultaneously.

A typical WPSN node hardware is represented in Fig. 1. The WPSN node hardware differs from the conventional WSN hardware basically on the power unit and the transceiver. In a conventional WSN node, the power unit is a battery. In the WPSN node, however, the power generator, which is an RF-to-DC converter [3], is an inherent part of the power unit and is the unique power source of the sensor node. Required power is obtained from the incident RF signal inducing a voltage on the receiver WPSN node. Then, as long as 100mV of voltage is induced on the receiving antenna [3], RF-to-DC converter yields DC power which is either used to wake up and operate the receiver, sensing and processing circuitries of sensor node, or kept in a charge capacitor to be used later.

The transceiver of a conventional WSN node is typically a short range RF transceiver. Compared to the other units of the node, the power consumption of the transceiver is considerably high. For this reason, in WPSN, MB, a passive and less power consuming method is adopted as the main communication mean. Here, the incident signal from the RF source is reflected back by the WPSN node. The node modulates this reflected signal by changing the impedance of its antenna [2], thereby transmits the data gathered from its sensing unit and processed by its processing unit, back to the RF source.

The transceiver for MB is much less power consuming and less complex, compared to conventional RF transceivers [2].

Furthermore, the maximum communication range of MB is determined by the intensity of the incident signal, and the sensitivity of the corresponding receiver. Thus, long range communication with the WPSN node is theoretically achievable without increasing the power consumption of the node. In a WPSN deployment, let P_r and P_t be the received power on the passive sensor node and the transmitted power by the RF source, respectively. Then, the RF signal propagates according to Friis' transmission equation [4].

$$P_r = P_t G_t G_r \left(\frac{\lambda}{4\pi R_{rf}} \right)^2 \quad (1)$$

Where G_t and G_r are the antenna gains, λ is the wavelength, i.e., the ratio of the speed of light c to the frequency f , and R_{rf} is the distance between the RF source and WPSN node.

Let the voltage induced on the antenna of WPSN node due to incident signal from RF source be V_r . Then, the relation between the received RF power P_r and the induced voltage level V_r is expressed as [4].

$$P_r = \frac{|V_r|^2}{8(R_r + R_t)} \quad (2)$$

Where R_r and R_t are the impedances of the antenna of WPSN node and the RF source, respectively.

According to (1) and (2) and for 4W effective isotropic radiated power (EIRP) output power of RF source, $R_t = R_r = 50\Omega$, $G_t = G_r = 8.5\text{dBi}$; it is calculated that 100mV can be induced on the antenna of WPSN node from 6.75m at 2GHz, 13.49m at 1GHz, and 26.98m at 500MHz, respectively. These calculated range values clearly demonstrate that multiple RF sources are needed for the practical implementation of a WPSN deployed over a large event area. Therefore, the required number of RF sources, for a given network size and communication parameters, needs to be determined for sufficient RF coverage, and hence, effective communication in WPSN.

3. Network Coverage

N sensor nodes are assumed to be randomly distributed over an event area of size Δ . Communication range of each RF source is represented by a circle of radius R_{rf} . The RF-to-DC converters of WPSN nodes in the range of an RF source are successfully activated by the source, and hence, they are able to reflect the collected data back to the RF source.

Here, the ranges of RF sources are considered to be non-overlapping to avoid interference between adjacently deployed RF sources. Source-to-source interference is illustrated in Fig. 2(a). Receiving both the reflected signal from the WPSN node and the strong signal from the source S_1 causes interference at source S_2 . Similarly, source-to-node interference is shown in Fig. 2(b). Communication with two RF sources simultaneously causes interference at the WPSN node k . In both cases, communication reliability is hampered due to loss and channel errors. Therefore, in order to avoid these two types of interference, RF sources must have non-overlapping circular ranges of R_{rf} in this analysis. Thus, each passive node is fed by

only one RF source in this case. Note that, in fact, if WPSN nodes were fed by multiple RF sources, passive sensor nodes would be able to store more energy in a faster way, and it would be easier for the nodes to receive, store, and transmit power, which would reduce the required number of RF sources for successful communication coverage. Therefore, non-overlapping RF source ranges lead us to the worst-case analysis in this case.

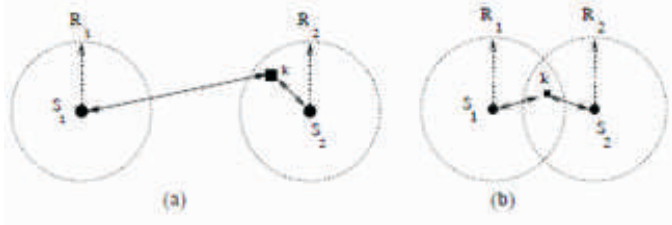

Figure 2: (a) Source-to-Source interference
(b) Source-to-Node interference

Let k be the required number of RF sources to provide MB-based communication coverage over the entire event area of size Δ . Then,

$$k = \frac{\Delta}{\pi R_{rf}^2} \quad (3)$$

Where R_{rf} is the communication range of an RF source.

Substituting (3) for R_{rf} into (1), and then using (2), the required number of RF sources for communication coverage in WPSN, i.e., k , can be obtained as

$$k = \frac{2\pi\Delta f^2 |V_c|^2}{c^2 P_t G_t G_r (R_r + R_t)} \quad (4)$$

Where f is the carrier frequency of the RF source, c is the speed of light c , i.e. $\lambda = \frac{c}{f}$.

Consequently, (4) can be used to determine appropriate design parameters for effective communication coverage in WPSN as will be shown next.

4. Numerical Analysis

Here, the required number of RF sources, i.e., k , is investigated for varying event field Δ , RF frequency f , output power P_t . Note that in order to minimize the overall energy consumption in WPSN, the output power of RF sources needs to be minimized. In this case, for the minimum output power which is just sufficient to induce the necessary voltage, i.e., $V_{\min} = 100\text{mV}$, on the receiver of the WPSN nodes, as discussed in Section II, the range of RF sources will be minimum. Therefore, for the worst-case analysis V_c is set to be 100mV . Unless otherwise stated, the remaining simulation parameters are $\Delta = 4 \times 10^4 \text{m}^2$, $R_r = R_t = 50\Omega$, $G_t G_r = 8.5\text{dBi}$, and $c = 3 \times 10^8 \text{m/s}$ [3], [4].

A. RF Source Output Power

Increasing the RF output power P_t means increasing the range R_{rf} as in (1). An event field can be covered by a smaller number of RF sources if the communication range of RF sources is increased. In Fig. 3(a), k decreases with increasing P_t , and hence, increasing R_{rf} range. Moreover, this shows that k increases with carrier frequency for a specific P_t value. This is because WPSN nodes use

more energy from RF sources when the communication rate is increased.

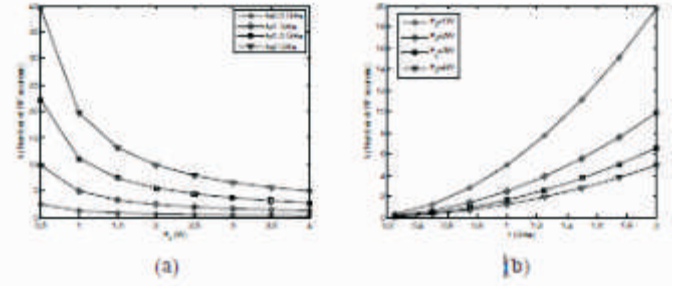

Figure 3: Variation of k with (a) RF output power
(b) carrier frequency

B. Carrier Frequency

As in Fig. 3(b), for a given network dimension and RF output power, increasing carrier frequency mandates an increase in the number of RF sources. This is mainly because WPSN nodes become able to use a higher data switching frequency, hence a higher data rate, and the energy consumption for data communication increases. Furthermore, k can be reduced by increasing the output power at a given RF frequency. When output power is increased, the range of RF sources increases, and they start to transmit with higher energy. As a result, each RF source is able to communicate with more WPSN nodes, and a smaller number of RF sources are required for communication connectivity over the event field.

On the other hand, the dependence of the required RF output power on frequency and number of RF sources is illustrated in Fig. 4. The results show the practical applicability of various carrier frequencies with k , in terms of practical values for RF source output power, with an increased number of RF sources, lower RF output power suffices to cover the event field, and hence k decreases. On the other hand, for higher frequencies, RF sources transmit with higher RF output power, because signal fading increases at high frequencies [4], [5] and also data communication is performed at a higher rate. These results and observations show that, for a typical WPSN implemented in an area of 40000m^2 and communicating with $f = 1\text{GHz}$, only 5 RF sources are required at an output power of 1W , as shown in Fig.4.

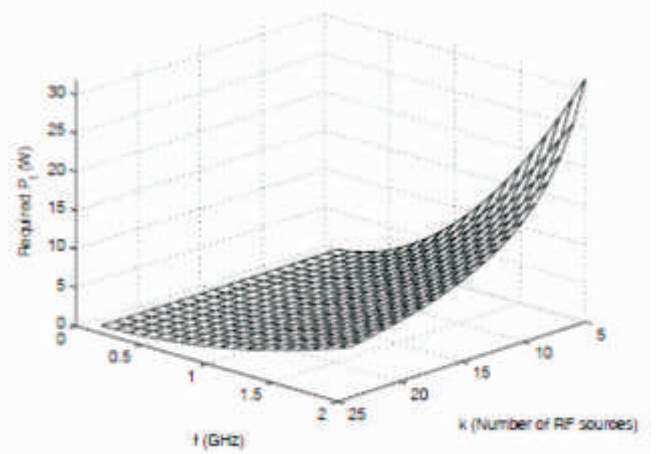

Figure 4: Required RF power for number of RF sources and frequency.

The maximum number of RF sources to achieve communication connectivity in the WPSN increases with RF communication frequency since more RF energy is required for the communication of collected data at a higher rate.

Increasing the size of the event field also increases the required number of RF sources for a given output power, because RF sources with a given output power have a limited range determined by their output power, and more such RF sources are needed to cover a larger area. On the other hand, the required number of RF sources decreases with output power. If RF sources transmit at a higher output power, they are able to satisfy (2) for WPSN nodes at a larger distance, hence, their range is increased. This means that the event field can be covered with a smaller number of RF sources.

C. Event Area

As shown in Fig. 5, increasing the network size necessitates communication connectivity over a larger area, and this requires more RF sources, since the range of each RF source is limited by its output power. Consequently, while the results are intuitively not surprising, the analysis shows that the theoretical result in (4) is applicable for the design of practical WPSN deployment cases.

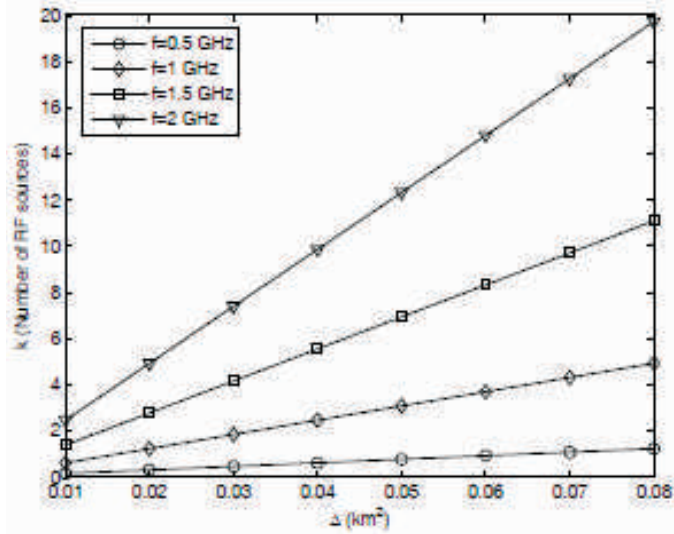

Figure 5: Variation of k with respect to the area of the event field

5. Conclusion

In this letter, RF communication coverage in WPSN is analyzed. The required number of RF sources for effective modulated backscattering-based communication in WPSN is determined in terms of the dimension of the event field, RF communication frequency, and RF output power. The analysis developed here can be used towards determination of design strategies of battery-free WPSN as well as radio frequency identification (RFID) networks.

6. References

1. I. F. Akyildiz, W. Su, Y. Sankarasubramaniam, and E. Cayirci, "A survey on sensor networks," *IEEE Commun. Mag.*, vol. 40, no. 8, pp. 102-114, Aug. 2002.
2. M. Kossel, H. R. Benedickter, R. Peter, and W. B'achtold, "Microwave backscatter modulation systems," *2000 IEEE MTT-S Digest*, vol. 3, pp.1427-1430, June 2000.
3. F. Kocer, P. M. Walsh, and M. P. Flynn, "Wireless, remotely powered telemetry in 0.25m CMOS," in *Proc. IEEE Radio Frequency Integrated Circuits Symposium (RFIC)*, pp. 339-342, June 2004.
4. C. A. Balanis, *Antenna Theory: Analysis and Design*, 2nd ed. John Wiley and Sons Inc., 1997.
5. K. Han, Y. Choi, S. Choi, and Y. Kwon, "Power amplifier characteristic aware energy-efficient transmission strategy," *Lecture Notes in Computer Science*, vol. 4479, pp. 37-48, Springer, Nov. 2007.