

Ethernet Based Embedded Application for Receiver Processor Unit

Ashok Ellandula¹, Pankaj Kumar Salla², Sreenivasa Rao Ekkurthi³

¹P.G Scholar, E.C.E Department, Vasavi College of Engineering (Autonomous),
Hyderabad, Telangana, India

²Defence Electronics Research Laboratory, Hyderabad, Telangana, India

³Professor, E.C.E Department, Vasavi College of Engineering (Autonomous),
Hyderabad, Telangana, India

Email: e.sreenivasarao@staff.vce.ac.in³

Abstract: Electronic Warfare (EW) systems are used to meet the tactical and strategic requirements of the users for use on different platforms like ships, aircrafts, helicopters, ground vehicles and submarines. The ES system will have broad band and narrow band operations to meet the tactical and strategic needs of EW systems. Broad band operation is achieved by employing a Wide Open Receiver, which will achieve 100% Probability of Intercept (POI), whereas narrow band receiver will help in achieving higher sensitivity and better Range Advantage Factor (RAF) against Low Probability of Intercept (LPI) radars. Receiver Processor Unit (RPU) generates the controls for the Digitally Tuned Oscillator (DTO) and the switches in the Built In Test Equipment (BITE) distribution network based on the BITE Command received from System Controller Display (SCD). The output of the RF Source is fed to the programmable attenuator to adjust the power levels required to check the dynamic range of the receiver. In this paper, the authors report development of an embedded application for RPU to generate the controls for various devices like switch filter bank, homodyne receiver etc. The embedded application is thoroughly tested for its functionality using given lookup table and the results are found to be satisfactory.

Keywords: Electronic Support Measure Processor (ESMP), Homodyne Receiver, Receiver Processor Unit (RPU), Switch Filter Bank (SFB), System Controller Display (SCD), Quad Super Heterodyne Receiver (QSHR).

I. INTRODUCTION

In the earlier systems, it was sufficient to have serial communication (RS -232) [1-2] as there were few threats prevailing in the environment and it so happened that the threat characteristics were not complex in nature. So the data flow (updates from ES) was rather slow and the serial link

was suiting the demand. The modern threats (radars) transmit very complex waveforms, such as Chirp (linear FM), Pseudo random sequence (baker, phase coded) within the pulse for making jammer difficult to handle them. The ES should extract these features from the waveform and classify the threat in order to take counter action. The more information extraction of the signal link definitely increases the size of data on serial link would take a definite amount of time. So the jammer cannot immediately take the action against the threat. Even though serial port is harder to program than the parallel port this is the most effective method in which the data transmission requires less wire which yields to less cost. The RS-232 is communication line which enables the data transmission by only three wire links. The three links provides transmit, receive and common ground. The transmit and receive lines on this DB-9 connector send and receive data between the computers. The disadvantages of Rs-232 communication are that the speed is very low (up to 20kbps), covers less distance, used for small area networks and serial communication only. In this paper, it is proposed a new method that is ETHERNET communication to achieve faster data rates when compared to RS-232. The frequency scheme for the RPU is proposed to provide high parameter measurement accuracy over 360 degree spatial coverage (90degree for each array) has been explained in the following.

In the ES (Electronic Support) segment, the frequency coverage of 0.175-40GHz is achieved in the split bands of 0.175-2.2GHz , 2.2-18 GHz (Broadband Receivers), 2.2-6 GHz, 6-18 GHz (Narrowband Receivers), and 18-40 GHz. The EA (Electronic Attack) system will be realized in two split bands, 6-18 GHz and 18-40 GHz band. Since number of threat Radars will be more in 6-18 GHz band and the ship is vulnerable over 360 degrees. In 18-40 GHz band, the number of threat Radars is very few and the operational range of the Radar is also less. Four sets of direction finding antenna arrays (2.2-18, 2.2-6 & 6-18 GHZ) housed in an Antenna HEAD Unit (AHU) are proposed to be mounted on the Pole mast of the platform.

Dipoloop Antenna (0.175-2.2 GHz) and Biconical Antenna (18-40 GHz) are stacked together and four such stacked antennas are proposed to be mounted on the Yard Arms of the main mast of the ship or on other structures in a Square/Rectangular configuration with a minimum span of 10 Meters. In 2.2-18 GHz BB channel, the simulated RF is simultaneously fed to the four Homodyne receivers. The RPU receives the computed data in the Homodyne receiver and sends the PD Data to the ESM Processor on OFC and the Health status of the Channel (FER, Homodyne Receiver, and RPU) to the SCD on the Ethernet. In 2.2-6 GHz NB channel and 6-18 GHz NB channel, the RF signal generated by the network is fed to the 2.2-6GHz switch matrix and 6-18 GHz switch matrix respectively. The switch matrix feeds the RF into QSHR which generates the IF corresponding to the fed RF. This IF is processed by the Digital Receivers to generate the detailed pulse parameters. Homodyne Receivers employ Base Line Interferometer (BLI) technique in 2.2-18 GHz band for interception, analysis and high accuracy DOA measurement.

II. PROPOSED SYSTEM LEVEL BLOCK DIAGRAM

Block diagram of the proposed system is shown in Fig. 1. Commands are fired by using System Controller Display (SCD). SCD is Graphical User Interface (GUI) that resides in a personal computer. Electronic Support Measure Processor (ESMP) communicates with the SCD and sends the commands to Receiver Processor Unit Board through Ethernet cable. Developed embedded application resides in the flash memory of RPU Board. When the board is switched ON embedded application runs automatically as it is already present in the flash memory of the RPU Board. The embedded application is developed using C language. The application sends an acknowledgement to SCD for handshaking purpose. Suppose when threshold command is fired, RPU sends the controls

for homodyne receiver. Similarly, other controls are sent to corresponding devices for executing the commands.

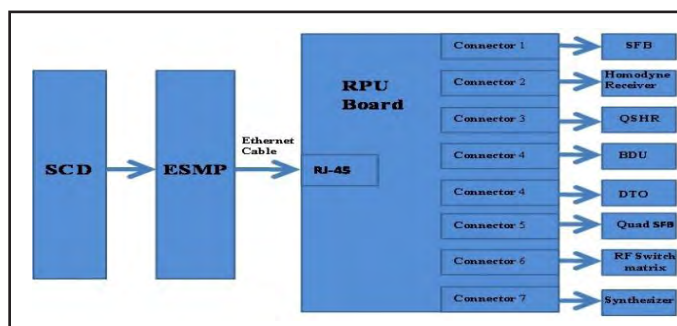

Fig. 1. System level block diagram

Fig. 2. shows internal details of RPU which is the main component of the proposed system. It contains the following hardware components.

FPGA. Xilinx 1738 pin Virtex-5 FXT family FPGA (XQ5VFX200T-1FF1738I).

Memory Elements. 16M × 16-bit, 200 MHz, DDR-2 memory on-board. Two on board 256Mb parallel Flashes

Clocks. 1.50MHz and 100MHz fixed single ended clocks to the FPGA.

Ethernet. Two 10/100/1000 Mbps Ethernet channel terminated using RJ45 connector on front panel.

Power. Input power - 5V/6A. Sourced from on board micro-D connector, all required voltages derived from on-board DC-DC converters and on board power monitoring circuitry.

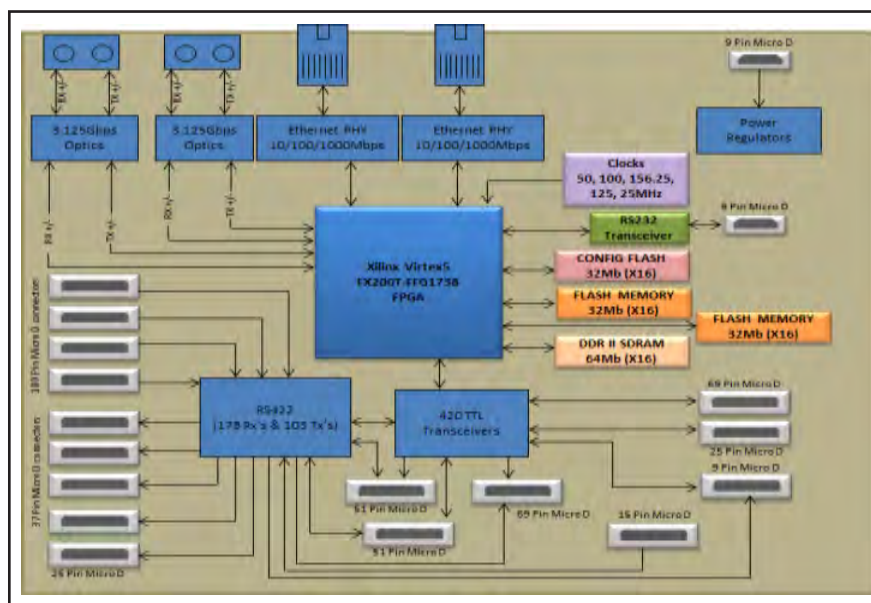

Fig. 2. Internal structure of RPU board

III. IMPLEMENTATION PROCESS FOR DEVELOPING EMBEDDED APPLICATION

The implementation process is shown in Fig. 3 in the form of flowchart. Base System Builder (BSB) wizard is used to create the required hardware platform for RPU. Hardware platform includes FPGA, DDR2 Memory, FLASH Memory, CONFIG-FLASH Memory, RS-232 Port, Block RAM, Timer interrupt, Ethernet MAC d etc. User Constraints File (UCF) is written for each hardware device by using Embedded Development Kit (EDK). Then, EDK generates a bit file which is used to program the FPGA.



Fig. 3. Configuration of embedded system processor

Custom IP core is an Intellectual Property created by the user in EDK environment. This Custom IP core contains several registers in it and each register is of 32 bit wide. The entire hardware design (bit file) is exported into Software Development Kit (SDK). SDK is used to build and run the embedded application. After thoroughly testing the application, it is fused permanently into CONFGI-FLASH Memory.

IV. COMMANDS IMPLEMENTED FOR RPU

The commands for the RPU are broadly classified into 2 categories namely broadband receiver commands and narrowband receiver commands. There are four broadband receiver commands namely SFB selection, Threshold selection, Bite On/Off and Mode selection. Similarly there are four narrow band commands namely Directed mode, Configure List Frequency mode, Narrow band Bite On/Off and RFPS Bite On/Off. The details of the commands like command

code, parameters and command name for the broadband and narrowband commands are shown in Table 1 and Table 2 respectively.

TABLE I
BROAD BAND RECEIVER COMMANDS

S.No	Command/Message Name	Parameters	Command Code
1	SFB Selection	Sfb controls	0x201
2	Threshold Selection	Threshold	0x202
3	Bite On/Off	Bite On, BITE Frequency, Pulse or CW, Bite Power Level, Quadrant Selection.	0x203
4	Mode Selection	Mode selection, Channel selection, SFB controls, Threshold.	0x205

TABLE II
NARROW BAND RECEIVER COMMANDS

S.No	Command/Message Name	Parameters	Command Code
1	Directed Mode	RF Frequency, RF Attenuation, IF Attenuation, Dig Rx Threshold, IF BW selection, Quadrant selection.	0x206
2	Configure List frequency Mode	No.of Frequency sets, RF Frequency, RF Attenuation, IF Attenuation, Dig Rx Threshold, IF BW selection, Dwell time.	0x207
3	NB BITE On/Off	Bite On, BITE frequency, RF attenuation, IF attenuation, Dig Rx threshold, IF BW Selection, Pulse or CW, BITE power level, Quadrant selection.	0x208
4	RFPS 2-18 Bite On/Off	Bite on , Bite Frequency, Pulse or CW, Bite Power Level.	0x20A

Each Command Consists of Header, Message Body and Footer. Header Consists of Start of Frame, Command Code, Sequence number and length of the message body. Message Body is nothing but Command's data information. Footer is present

after the message body. The command frame format is shown in Fig. 4. Each Command is identified by its command code and message length. No two commands would have same command code. Fig. 6 shows the fields in command frame.

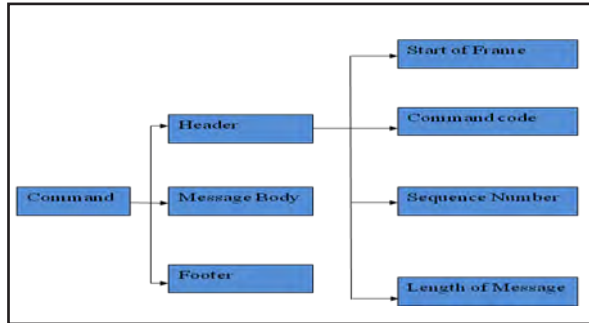

Fig. 4. Command frame format

V. TESTING OF RPU COMMANDS

Fig. 5 is the test setup we used for testing the RPU commands. Wire shark software tool is used for capturing the Ethernet command frames fired from the SCD. The embedded application analyses the command frames and verifies its functionality using lookup tables. The ethernet data rate may be set at 10/100/1000 Mbps in the EDK tool.

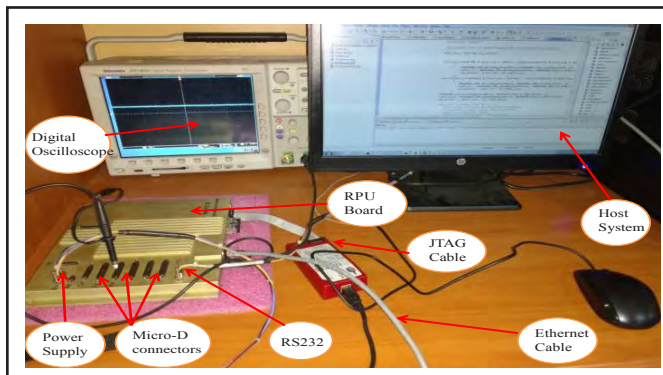

Fig. 5. Testing setup

VI. DISCUSSION OF RESULTS

A. Broadband Receiver Command Results

The input parameter values for Bite On/Off command is shown in Fig. 7 for an Ethernet data rate of 1 Gbps which is set in EDK tool. The command frame captured by Wire shark software tool is shown in Fig. 8. The output on Tera term (Hyper terminal) is shown in Fig. 9. It may be observed from Fig. 9 that tuning frequency is 31050 MHz, DTO_VCO is 0 and DTO_Latch is 1. It is very clear from the given lookup table that the output results obtained are in good agreement. Similarly, the results for all other broad band commands are also verified.

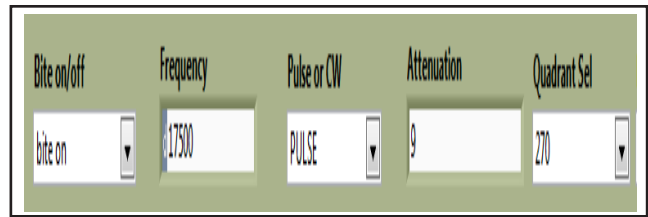

Fig. 7. Input from SCD for bite on/off command

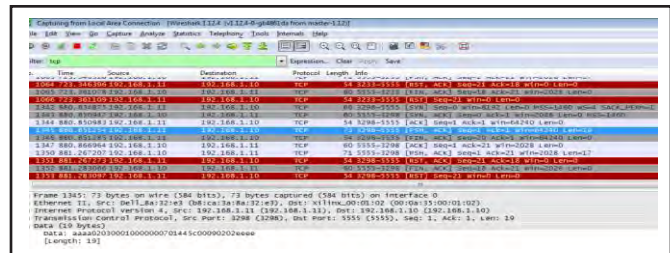

Fig. 8. Bite on/off command frame



Fig. 9. Output for bite on/off command on tera-term (hyper terminal)

B. Narrowband Receiver Command Results

The input parameter values for Configure List Frequency command is shown in Fig. 10 for an Ethernet data rate of 1 Gbps, which is set in EDK tool. The command frame captured by Wire shark software tool is shown in Fig. 11. The output on Tera term (Hyper terminal) is shown in Fig. 12. It may be observed from Fig. 11 that for frequency set-1, synthesizer frequency is 64000 MHz, Band select is 2, SFB is 2 and for frequency set- 2, synthesizer frequency is 54000 MHz, Band select is 2, SFB is 0. It is very clear from the given lookup table that the output results obtained are in good agreement. Similarly, the results for all other narrow band commands are also verified.

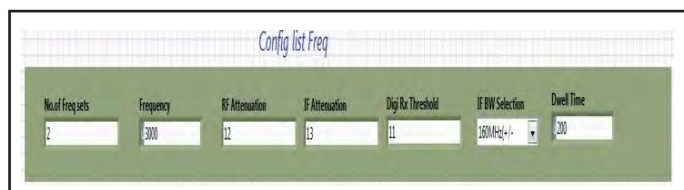

Fig. 10. Input from SCD for configure list frequency command

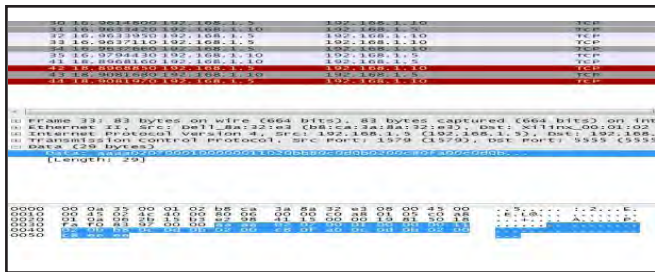

Fig. 11. Configure list frequency command frame



Fig. 12. Output for configuration list frequency command on tera-term

VII. CONCLUSIONS

Base System Builder (BSB) wizard is used to create the required hardware platform for RPU. User Constraints File (UCF) is written for each hardware device by using Embedded Development Kit (EDK). Hardware platform includes FPGA, DDR2 Memory, FLASH Memory, CONFIG-FLASH Memory,

RS-232 Port, Block RAM, Timer interrupt, Ethernet MAC etc. The entire hardware design (bit file) is exported into Software Development Kit (SDK). Embedded application for RPU is written using embedded C for processing and verifying the commands. Broad band and narrow band receiver commands are implemented and tested successfully with 10/100/1000Mbps Ethernet speeds. It is obvious that as compared to Serial communication, Ethernet based communication works fast.

ACKNOWLEDGEMENT

ECE Department of Vasavi College of Engineering wishes to express gratitude to S.R. Pankaj Kumar (SC-F), DLRL for giving the opportunity to our M.E. student to carry out his project. The authors wish to express their gratitude to the Director, DLRL. The Authors also wish to express special gratitude to K.Sriram, employee of RADIX Micro Systems for all the support and encouragement to carry out this work.

REFERENCES

- [1] <http://www.fmf.unilj.si/~ponikvar/STM32F407%20project/SerialCommunication-RS232.pdf>
- [2] H.-I. Peng, Y.-L. Nie, "Design of serial communication interface based on FPGA," In *IEEE International conference on Computer Science and Automation Engineering (CSAE)*, pp. 410-414, 2011. IEEE Press, Shanghai.
- [3] W. Stallings, *Data and Computer Communications*, 3rd ed. New York, 1994.
- [4] A. S. Tanenbaum, *Computer Networks*, 3rd ed. Prentice Hall 1996.
- [5] Y. P. Kanetkar, *Let Us C Computer Science Series*, 8th ed. 2008.
- [6] Receiver Processor Unit components data sheets. Available: <http://www.xilinx.com>