

Enhanced BER Analysis and Interference Cancellation in SFBC-OFDM with Timing Offset

N. Sreekanth

Professor, Department of ECE, MRECW, Secunderabad, Telangana, India.
 Email: nsreeku@gmail.com

Abstract: In this paper, we proposed an iterative receiver for MIMO-OFDM systems. Based on this receiver, solutions to two of the most important problems in OFDM systems have been provided, namely, inter carrier interference cancellation and inter symbol interference cancellation over time-selective and frequency-selective fading channels. This work describes the development of a novel ICI and ISI mitigation technique in MIMO-OFDM systems with timing offset algorithm for OFDM systems. Among the previously mentioned issues, this section tends to the development of timing estimation algorithm with increased accuracy and decreased computation complexity for LTE downlink application. In this topic we consider an SFBC-OFDM system with timing offset (μ), derive the mathematical expressions for the interference provoked and propose the interference cancelling receiver. The influence of timing offset (μ) on a MIMO-OFDM system has been derived theoretically and evaluated from results of Bit Error Rate (BER) simulations.

Keywords: ICI, ISI, MIMO-OFDM, Timing Offset.

I. INTRODUCTION

The combination of OFDM with SFBC allowed the creation of codes known as SFBC-OFDM offering low decoding complexity and bandwidth efficiency as realized in SFBC for single carrier systems. STBC-OFDM and SFBC-OFDM systems have been adopted by standard such as WiMax and 4G and have been under extensive investigation by researchers.

A. OFDM

Consider the carriers $\cos(2\pi k f_c t)$ for integer values of k . These carriers are orthogonal in the interval $T = \frac{1}{f_c}$. If we sample the pre-envelopes of these carriers in such a way that there are N samples in the interval T , we get N different complex exponential carriers given by $e^{\frac{j2\pi kn}{N}}$, $1 \leq k \leq N$. These carriers are orthogonal over N samples. The complex envelope of this

set of carriers gives their complex base band representation, given by $e^{\frac{j2\pi kn}{N}}$, $0 \leq k \leq N-1$. If we modulate the k^{th} carrier by a complex symbol X_k , and collect the first N samples, we get the k^{th} modulated carrier sequence, given by [1] [2]

$$x_n^k = X_k e^{\frac{j2\pi kn}{N}}, 0 \leq n \leq N-1 \quad (1)$$

The sum of all the modulated carrier sequences is

$$x_n = \frac{1}{N} \sum_{k=0}^{N-1} X_k e^{\frac{j2\pi kn}{N}}, 0 \leq n \leq N-1 \quad (2)$$

Here, corresponding to a block of N complex symbols, we get a frame of N samples. To avoid the interference from the symbols of the previous frame when the sequence is transmitted through a multipath channel, the last N_g samples of x_n are placed before the first sample, where N_g is at least equal to the delay spread of the channel. This is called the Cyclic Prefix (CP). After adding CP, the sequence transmitted is given by

$$x_n^c = \frac{1}{N} \sum_{k=0}^{N-1} X_k e^{\frac{j2\pi kn}{N}} \quad -N_g \leq n \leq N-1 \quad (3)$$

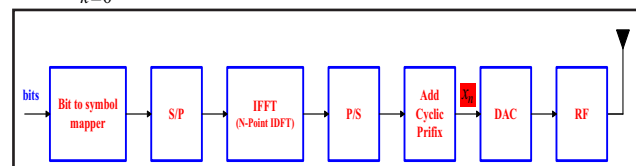

Fig. 1: OFDM Transmitter

This is an OFDM signal in which the carriers are called the subcarriers. Since eqn. (3) is the Inverse Discrete Fourier Transform (IDFT) equation, the discrete-time complex baseband processing part of the transmitter of a OFDM system contains a bit to symbol mapper, serial-to-parallel converter, IDFT unit and CP insertion unit followed by parallel-to-serial converter as shown in Fig. 1. In a practical system, the output is converted to an analog signal using a digital-to-analog converter (DAC), translated in to Radio Frequency (RF) spectrum and transmitted. With x_n^c transmitted through a L -path frequency-selective channel with channel impulse response, $h = [h_0, h_1, \dots, h_{L-1}]$, it reaches the receiver through L paths as shown in the Fig. 2. The signal at the input to the receiver is given by

$$r_n = \sum_{\lambda=0}^{L-1} h_\lambda x_{n-\lambda}^c + w_n \quad (4)$$

Where, w_n is the Additive White Gaussian Noise (AWGN). With perfect timing of the processing window at the receiver, after performing the RF down conversion using the synchronous carrier and analog-to-digital conversion (ADC), the discrete-time baseband representation of the signal at the output of the processing window is given by

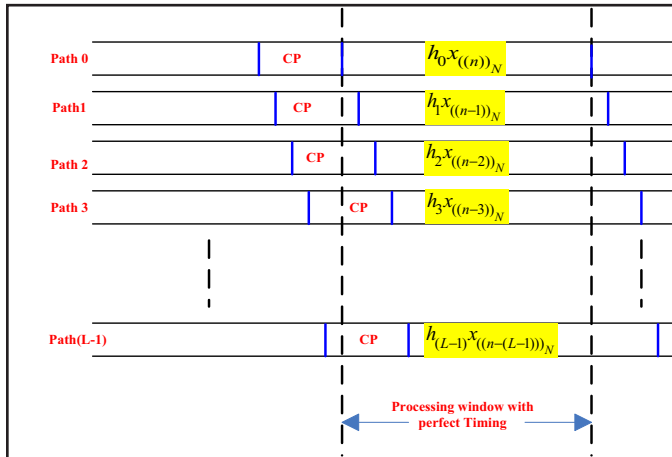

Fig. 2: Multipath Received Signal

$$y_n = \sum_{\lambda=0}^{N-1} h_{\lambda} x_{((n-\lambda))_N} + w_n, \quad 0 \leq n \leq N-1 \quad (5)$$

which is the circular convolution of h and x ($x = [x_0, x_1, x_2, \dots, x_{N-1}]$). The discrete time complex baseband processing part of the receiver of OFDM system with perfect synchronization is shown in Fig. 3. The k^{th} output of N -point DFT unit in the receiver is given by

$$Y_k = X_k H_k + W_k \quad (6)$$

Where, H_k is the frequency response of the channel for k^{th} subcarrier, given by

$$H_k = \sum_{n=0}^{L-1} h_n e^{-i2\pi kn/N} \quad (7)$$

The k^{th} transmitted symbol is detected using $Y_k H_k^*$. For maximum-likelihood detection in case of non-constant envelope modulation alphabets such as M-QAM, $\frac{Y_k}{H_k}$ can be used (which also coincides with zero-forcing receiver).

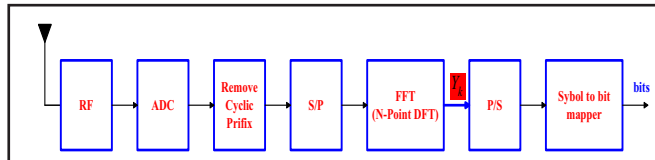

Fig. 3: OFDM Receiver

II. SFBC-OFDM SYSTEM MODEL

A. Introduction

In this section, SFBC transmit diversity technique is applied into the OFDM system. Simply, the 2Tx/1Rx antenna configurations are considered to the performance of the MIMO-OFDM system. Here, we discuss the traditional MIMO SFBC-OFDM structure with 2Tx/1Rx antennas. In this section, SFBC has been with QPSK digital modulation scheme. One popular representation of these codes is the Alamouti's scheme [3] for two transmit antennas.

i. Alamouti's Scheme with 2Tx-1Rx Antennas

Alamouti introduced a very simple scheme of SFBC allowing transmissions from two antennas with the same data rate as on a single antenna, but increasing the diversity at the receiver from one to two in a Rayleigh fading channel. As shown in Fig. 4, the Alamouti's algorithm uses the space and frequency domain to encode data with increase in the performance of the system by coding the signals over the different transmitter branches [3]. Thus, the Alamouti's code achieves diversity two with full data rate as it transmits two symbols in two frequency slots as shown in the Table I. The received vector, R , is formed by stacking two consecutively received data samples in frequency, resulting in

$$R = Sh + w \quad (8)$$

where $R = [r_0, r_1]^T$ represents the received vector [3],

$h = [h_1, h_2]^T$ is the complex channel vector, $w = [w_1, w_2]^T$ is the noise at the receiver and S defines the SFBC.

TABLE I: ALAMOUTI'S SFBC WITH TWO TRANSMIT ANTENNAS

	Symbol Transmitted on Antenna (1)	Symbol Transmitted on Antenna (2)
Subcarrier, k	s_k	s_{k+1}
Subcarrier, $k+1$	$-s_{k+1}^*$	s_k^*

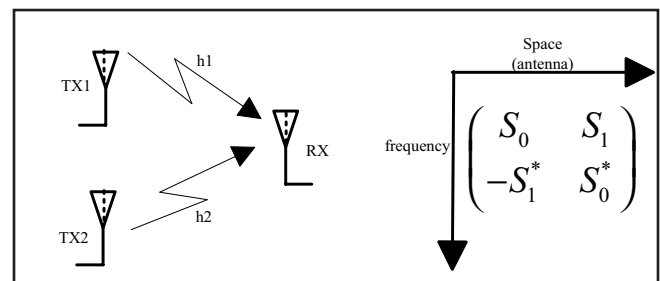

Fig. 4: Transmit, 1-Receive Alamouti SFBC Coding

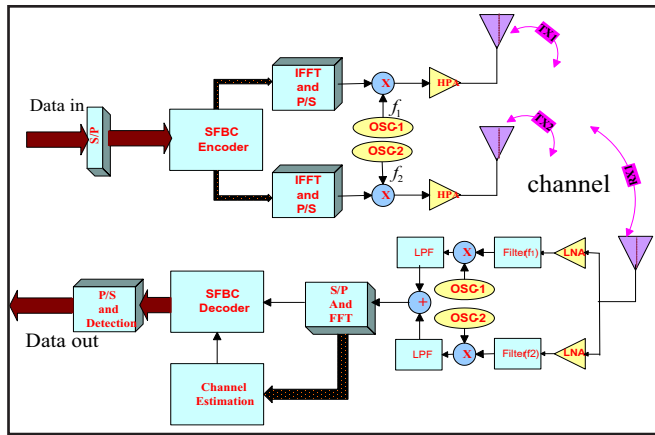

Fig. 5: 2 x 1 SFBC-OFDM Transceiver

Due to this orthogonality, the Alamouti's scheme decouples the MISO channel into two virtually independent channels with channel gain h^2 and diversity $d = 2$ is as shown in the Fig. 5 [4]. The channel gain specifies that transmitted symbols can be estimated at the receiver as the result of multiplying the received signals by the Hermitian of the virtual channel matrix. After performing the corresponding operations it results in a signal with a gain of h^2 plus some modified noise.

$$\hat{s} = h^2 I_2 s + \hat{w} \quad (9)$$

Where, s is the transmitted signal, I_2 is the 2×2 identity matrix,

$$h^2 = |h_1|^2 + |h_2|^2$$

$$\text{and } \hat{w} = \begin{pmatrix} h_1^* w_0 + h_2 w_1^* \\ h_2^* w_0 - h_1 w_1^* \end{pmatrix} \text{ is modified noise.}$$

ii. Simulation Results

Simulations have been performed under multipath frequency selective channels and results are obtained in terms of BER versus SNR. The simulation parameters used for SFBC-OFDM are shown in Table II.

TABLE II: SIMULATION PARAMETERS FOR SFBC-OFDM

FFT Size	64
Number of active subcarriers	52
Band width	16 MHz
Channel	Rayleigh
Sampling rate (f_s)	0.4 MHz
Distance between adjacent subcarrier (Δf)	312.5 kHz
Symbol duration	3.2 μs
Guard time	0.8 μs
Total symbol duration	4 μs
Modulation	QPSK
Transmit antenna	2
Receive antenna	1

The plot shown in Fig. 6 shows the BER comparative performance of Alamouti's SFBC-OFDM in different channel situations. The 2 TX and 1 RX SFBC-OFDM with Rayleigh channel shows outperformance than standard OFDM system.

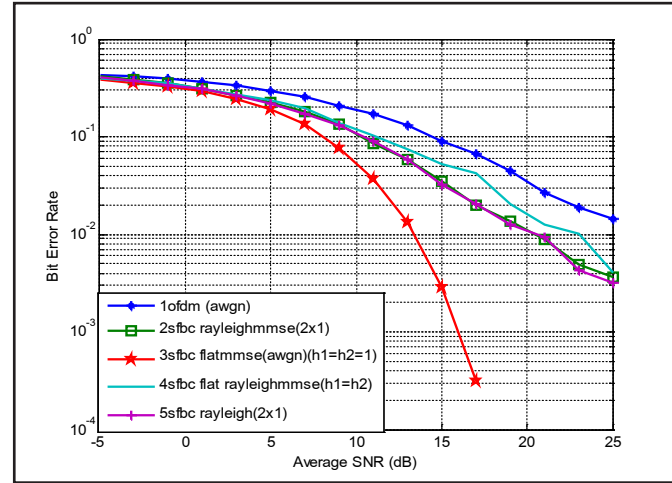

Fig. 6: BER Performance of 2 x 1 Alamouti SFBC-OFDM

In the next section, we are concerned with the detection of SFBC-OFDM signals on time and frequency-selective MIMO channels. Specifically we proposed and evaluated the performance of an interference cancelling receiver for SFBC-OFDM which effectively alleviates the effects of ISI and ICI.

III. METHODOLOGY

The SFBC-OFDM presented in the literature assumes excellent timing synchronization i.e. the frames transmitted by two transmitting antennas appear at the same time at the receiver. This is very onerous to achieve in a practical system and requires lot of time and feedback channel bandwidth. Moreover, when there is an instant adjustment in the channel in a wireless mobile communication system the synchronization gets disturbed. Because of this the frames transmitted by two antennas arrive at different time intervals which we regard as the timing offset [5].

The system with timing offset, the system gets synchronized to the frame transmitted by one antenna but the synchronization is lost for the frame transmitted by the other antenna. The other frame which arrives with the timing offset may appear at the receiver, before or after the frame with perfect synchronization. In the first case we call the timing offset as negative ($\mu = 0$) and in next case we call it as positive ($\mu = 0$) is illustrated through processing window in Fig. 7 [5]. For various values of μ the expressions for the interference terms are different.

In this we propose the derivation for one case where the frame transmitted from the second antenna arrive with positive timing offset and present the interference mitigating receiver for such a system. To derive these expressions we examine the SFBC

system with N -subcarriers in which the complex symbol vector transmitted is $X = [x_0, x_1, x_2, \dots, x_{N-1}]$. After SFBC Alamouti (2X1) coding we get two vectors given by

$v_1 = [v_0^1, v_1^1, v_2^1, \dots, v_{N-1}^1]$ in which $v_n^1 = x_n$, where $n=0, 1, 2, \dots, N-1$ and $V_2 = [v_0^2, v_1^2, v_2^2, \dots, v_{N-1}^2]$ in which $v_n^2 = x_{2n+1}^*$ for n even and $v_n^2 = -x_{2n}^*$ for n odd, where $n=0, 1, 2, \dots, N-1$.

And the k^{th} output of the N -point FFT block at the receiver is given as

$$Y_1(k) = h_1 x(k) + W_1(k) \quad (10)$$

Similarly, the frame transmitted by the second antenna reaches the receiver through the Rayleigh flat faded channel with channel co-efficient h_2 with positive timing offset μ for which the frame sequences presented in the Fig. 7.

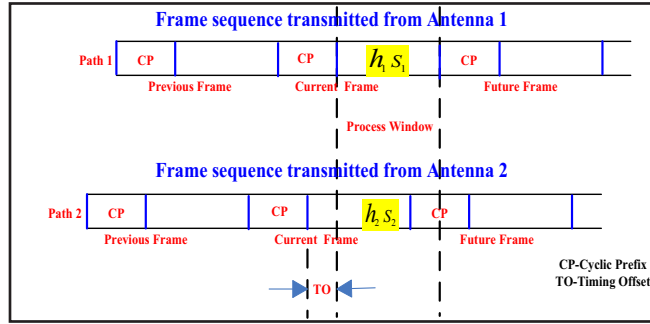

Fig. 7: Processing Window

IV. PROPOSED ALGORITHM

ICI Cancellation using Interference Cancellation (IC) Algorithm

Stage 1: Using $Y[k]$, the estimate of symbols $\hat{X}^1[q], \forall q = 0 \text{ to } N-1$ is obtained.

Stage 2: Using $\hat{X}^1[q]$ for each k and known $H[q]$, $ICI_1[k]$ is computed using the formulae $ICI_1[k] = \sum_{q=0}^{N-1} \hat{X}^1[q] H[q]$ and subtracted from $Y[k]$ to get $Y^1[k]$, where

$$\begin{aligned} Y^1[k] &= Y[k] - ICI_1[k] \\ &= \underbrace{V^2[k]H[k]}_{\text{Desired}} + \underbrace{\sum_{\substack{q=0 \\ q \neq k}}^{N-1} V^2[q]H[q]}_{ICI} + \underbrace{\sum_{q=0}^{N-1} V^{2f}[q]H^f[q]}_{ISI} + W_2(k) \\ &\quad - \underbrace{\sum_{\substack{q=0 \\ q \neq k}}^{N-1} \hat{X}^1[q]H[q]}_{ICI_1[k]} \end{aligned} \quad (11)$$

Stage 3: Using $Y^1[k]$, $X^2[q]$ is calculated. Using which, $ICI_2[k]$ is computed and subtracted from $Y[k]$ to get

$$\begin{aligned} Y^2[k] &= Y[k] - ICI_2[k] \\ &= \underbrace{X[k]H[k]}_{\text{Desired}} + \underbrace{\sum_{\substack{q=0 \\ q \neq k}}^{N-1} X[q]H[q]}_{ICI} + \underbrace{\sum_{q=0}^{N-1} X^f[q]H^f[q]}_{ISI} + W_2(k) \\ &\quad - \underbrace{\sum_{\substack{q=0 \\ q \neq k}}^{N-1} X^2[q]H[q]}_{ICI_2[k]} \end{aligned} \quad (12)$$

This process is repeated until we get considerable improvement in the performance of the system. In the similar way the ISI also can be cancelled.

V. SIMULATION RESULTS

In simulations we contemplate the 16-subcarrier SFBC-OFDM that uses Alamouti's coding with 2 transmit antennas and 1 receive antenna [3,6]. We simulated the system that has only ICI and assumed the perfect knowledge of channel co-efficient and timing offset.

The plot presented in the Fig. 8 obtained by simulations, in which the BER of the system is plotted as a function of SNR for different stages of the IC receiver. In this plot we can see considerable improvement in the BER performance of the system in the second stage itself, for example it is improving from 10^{-2} to 10^{-3} at 25 dB SNR. During the same SNR the improvement given by the third stage is less which becomes 5×10^{-4} . This shows that the performance of the SFBC-OFDM system with timing offset can be considerably improved using the IC algorithm developed in this work.

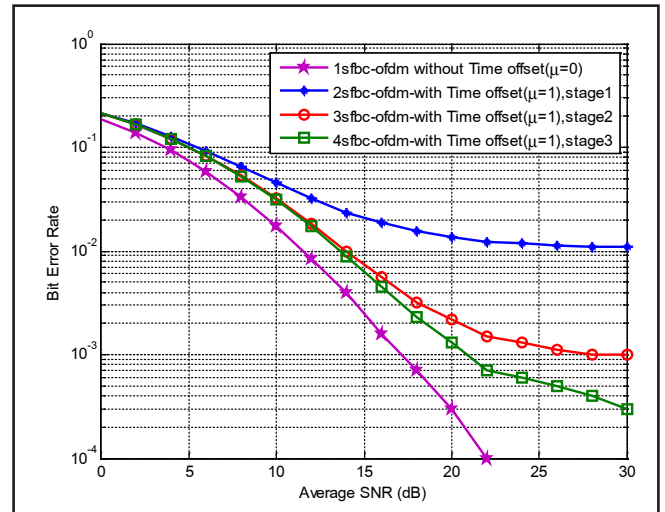

Fig. 8: BER Performance of the Proposed IC Detector in Rayleigh Flat Fading (QPSK)

VI. CONCLUSION

It must be noted that OFDM systems are sensitive to timing offset which induces the ICI problem. The design of robust timing offset mitigation algorithm without using additional training symbols will be a challenge. Although the interference suppression scheme and the channel parameter estimation scheme proposed in this paper can be applied to ICI cancellation effectively for MIMO-OFDM systems.

In this work, we described the development and simulation of an interference cancelling algorithm for cancelling frequency selectivity induced ISI and time-selectivity induced ICI in MIMO SFBC-OFDM systems with timing offset. In this work, the simulations showed that considerable performance improvement is achieved, which intern proves the fidelity of the expressions derived.

REFERENCES

- [1] L. Rugini, and P. Banelli, "BER of OFDM systems impaired by carrier frequency offset in multipath fading channels," *IEEE Trans. on Wireless Commun.*, vol. 4, no. 5, pp. 2279-2288, September 2005.
- [2] K. Raghunath, A. Chockalingam, and L. B. Milstein, "Uplink OFDMA without cyclic prefix: An interference cancellation approach," *Proc. Intl. Symp. on Commun. Contr. and Sig. Proc. (ISCCSP'2008)*, Malta, March 2008.
- [3] S. M. Alamouti, "A simple transmit diversity technique for wireless communications," *IEEE Journal on Selected Areas in Communications*, vol. 16, pp. 1451-1458, 1998.
- [4] D. Sreedhar, and A. Chockalingam, "Detection of SFBC-OFDM signals in frequency and time-selective MIMO channels," *Proc. IEEE WCNC'2007*, Hong Kong, March 2007.
- [5] K. Raghunath, and A. Chockalingam, "SIR analysis and interference cancellation in uplink OFDMA with large carrier frequency/timing offsets," *IEEE Transactions on Wireless Communications*, vol. 8, no. 5, May 2009.
- [6] A. Stamoulis, S. N. Diggavi, and N. Al-Dhahir, "Intercarrier interference in MIMO-OFDM," *IEEE Trans. on Signal Processing*, vol. 50, no. 10, pp. 2451-2464, October 2002.