

Analysis the Performance of MIMO-OFDM for Various Modulation Techniques over AWGN, Rayleigh Fading and Rician Fading Channel

Diponkor Bala^{1*}, G. M. Waliullah², Md. Hafizur Rahman², Md. Ibrahim Abdullah²
and Mohammad Alamgir Hossain²

¹Department of Computer Science and Engineering, Islamic University, Kushtia, Bangladesh.
Email: diponkor.b@gmail.com

²Department of Computer Science and Engineering, Islamic University, Kushtia, Bangladesh.
*Corresponding Author

Abstract: Nowadays, we are living in the era of modern communication technology. The number of the mobile users is increasing tremendously day by day all over the world. Due to the increasing of the mobile users, the wireless communication systems are highly required a communication system that provides data transmissions rates and more reliability to the users. Multiple Input and Multiple Output Orthogonal Frequency Division Multiplexing (MIMO-OFDM) is being considered to get those facilities. MIMO-OFDM has the ability to serve a large number of users with an enormous data transmission speed communication as well as utilizing the bandwidth efficiently. The multicarrier modulation technique is cap-able of reducing the inter symbol interference and multipath fading problems. In this paper, we mainly focused on analysis the performance of MIMO-OFDM systems and the performance of MIMO-OFDM has been measured in terms of the Bit Error Rate and Signal to Noise Ratio based on different channels such as- AWGN, Rayleigh fading, Rician fading and different modulation techniques such as- BPSK, QPSK, M-PSK, D-BPSK, D-QPSK, DPSK and QAM. All the simulations are performed by MATLAB framework.

Keywords: BPSK, D-BPSK, DPSK, DQPSK, M-PSK, MIMO- OFDM, OFDM, QAM, QPSK.

I. INTRODUCTION

The exploration for high data usage at a high speed transmission with extreme reliability is promptly aggregating in the modern world. The telecom providers witness this to be a dominant issue and are actively researching on an ideal solution [1] [2]. The OFDM is widespread over the decade and is one of the promising schemes. Its significance is prominent in areas such as reliability, robustness, frequency selective fading and provides ease of implementation [3] [4] [5].

In the recent years, the idea of using MIMO is protuberant as it uses multiple carrier technology. This uses multiple antennas at the transmitter as well as the receiver. The best received signal form a transmitter is chosen at the receiver. MIMO spreads an equivalent total transmit power over the antennas to realize an array gain that improves the spectral efficiency (more bits per second per hertz of bandwidth) or to realize a diversity gain that improves the link reliability (reduced fading). This thus provides high resolution and reliability. The fact that high data rate and high performance is necessary made wireless systems prefer MIMO to SISO (Single Input Single Output) [5] [6].

The MIMO-OFDM pair is regarded favorable, by wireless communication systems operating with a narrow band spectrum. In order to implement this in physical networks, a number of modifications is needed which may include time and frequency domain synchronization, channel estimation and MIMO detection [8].

The aim of this work is to classify the MIMO-OFDM systems based on their channel estimation and modulation techniques utilization. The modulation techniques BPSK, QPSK, M-PSK, D-BPSK, DQPSK, DPSK, and QAM are implemented in AWGN, Rayleigh, Rician channels. The performance is measured with respect to Bit Error Rate and Signal to Noise [2] [8].

All the simulations are implemented on MATLAB 9.0 (2016a) and the system configuration is Core i3-2.40 GHz processor with windows 10 based 64 bit operating system.

Rest of the paper is organized as follows: Section II describes about various channels, Section III explains about different modulation techniques, Section IV describes about the principle of MIMO-OFDM system, Section V presents the proposed work, Section VI shows the simulation results and discussion, and finally conclusion of this research work is drawn in Section VII.

II. CHANNELS

Depend on the fading environments and noise channel, the communication channel can be categorized into three types such as- Additive White Gaussian Noise (AWGN) channel, Rayleigh fading and Rician fading channel. In this paper, the performance of MIMO-OFDM has been analyzed with respect to these three types of channel.

A. AWGN Channel

The AWGN channel is very popular due to its non-fading properties and simplicity. The time of passing signals through the channel the AWGN channel adds White Gaussian noise to the signal [9] [10] [11]. The Probability density function is always following Gaussian distribution and the equation of Gaussian distribution is expressed as-

$$f_g(x) = \frac{1}{\sigma\sqrt{2\pi}} e^{-\frac{(x-\mu)^2}{2\sigma^2}} \quad (1)$$

Where x = Random variable

μ = Mean value

σ = Standard deviation

Through AWGN channel a received signal is expressed as-

$$r(t) = x(t) + n(t) \quad (2)$$

Where $x(t)$ = Transmitted signal

$n(t)$ = Additive White Gaussian noise

The model of the AWGN channel is shown in Fig. 1.

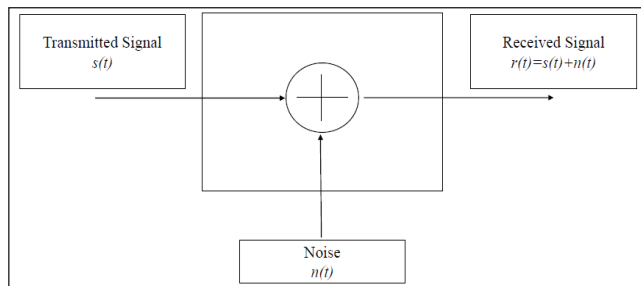

Fig. 1: AWGN Channel Model

B. Rayleigh Fading Channel

In a Rayleigh fading channel, the signal passing through the channel is distorted by a Rayleigh distribution. Multipath Reception is the root cause of Rayleigh Fading. The antennas receive a large number reflected and scattered waves. The effects of multipath causes constructive and destructive interference. Rayleigh fading is more accurate when there is a non-line of sight communication established between the transmitter and receiver [11]. The Probability density function (pdf) of the Rayleigh random variable is given by-

$$p(z) = \frac{z}{\sigma^2} e^{-\frac{z^2}{2\sigma^2}}, \text{ for } z > 0 \quad (3)$$

Where σ^2 is the time-Average Power of the received signal.

C. Rician Fading Channel

In Rician fading Channel the amplitude gain is characterized by the Rician distribution. Here the channel involves a line of sight signal between the transmitter and the receiver. The Rician fading occurs when one of the received signal is stronger (typically line of sight component) is stronger when compared to the other [11]. The Rician distribution is represented by the following equation.

$$p(r) = \frac{r}{\sigma^2} e^{-\frac{(r^2+A^2)}{2\sigma^2}} I_0\left(\frac{Ar}{\sigma^2}\right) \text{ for } (A \geq 0, r \geq 0) \quad (4)$$

Where A represents the peak amplitude of the dominant signal. $I_0[\cdot]$ is the modified Bessel function.

III. MODULATION TECHNIQUES

Modulation techniques play a significant role in wireless communications. It is a method of processing the data symbols to be transmitted in the carrier. Nowadays most of the wireless transmissions are in digital in nature and critical utilization of bandwidth is important. The type of modulation used plays a vital role in this step, where in the constellation determines the bandwidth usage [12]. One of the goal of modulation, is to achieve maximum spectral efficiency (i.e.) squeeze as much data into the least amount of spectrum possible. Spectral efficiency measures how quickly data can be transmitted in an assigned bandwidth. The unit of measurement is bits per second per Hz (b/s/Hz). Multiple techniques have emerged to achieve and improve spectral efficiency. In this project we use BPSK, QPSK, M-PSK, D-BPSK, DQPSK, DPSK, and QAM [13] [14].

A. Binary Phase Shift Keying (BPSK)

The Binary shift keying has two message signals. In BPSK, the transmitted signal is a sinusoid of fixed amplitude. It has one fixed phase when the data is at one level and when the data is at the other level, phase is different by 180° [15]. A Binary Phase Shift Keying (BPSK) signal can be defined as-

$$V_{BPSK} = \pm \sqrt{2P} \cos 2\pi f_c t, 0 < t < T \quad (5)$$

Where f_c is the carrier frequency, and T is the bit duration.

Signal power $P = \frac{A^2}{2}$, so that $A = (2P)^{\frac{1}{2}}$, where A represents the peak value of sinusoidal carrier.

The bit error rate-

$$P_b = \frac{1}{2} \operatorname{erfc} \left(\sqrt{\frac{E_b}{N_0}} \right) \quad (6)$$

B. Quadrature Phase Shift Keying (QPSK)

QPSK (Quadrature Phase Shift Keying) is type of phase shift keying. QPSK is a modulation scheme which sends two bits of digital information a time (without the use of another carrier frequency). The amount of radio frequency spectrum required to transmit QPSK reliably is half that required for BPSK signals, which in turn makes room for more users on the channel [16].

Hence, the signal constellation consists of the signal-space 4 points.

$$\pm \sqrt{E_s/2}, \pm \sqrt{E_s/2}$$

The factors of 1/2 indicate that the total power is split equally between the two carriers.

The Probability of error-

$$P_b = Q \left(\sqrt{\frac{2E_b}{N_0}} \right) \quad (7)$$

The probability of symbol error-

$$P_{SE} = 2Q \left(\sqrt{\frac{E_s}{N_0}} \right) - \left[Q \left(\sqrt{\frac{E_s}{N_0}} \right) \right]^2 \quad (8)$$

C. Quadrature Amplitude Modulation (QAM)

Quadrature amplitude modulation (QAM) conveys the two digital bit streams, by changing (*modulating*) the amplitudes of two carrier waves, using the amplitude-shift keying (ASK) digital modulation scheme or amplitude modulation (AM) analog modulation scheme. The two carrier waves, usually sinusoids, are out of phase with each other by 90° and are thus called quadrature carriers or quadrature components. The modulated waves are summed, and the final waveform is a combination of both phase-shift keying (PSK) and amplitude-shift keying (ASK). In the digital QAM case, a finite number of at least two phases and at least two amplitudes are used. Arbitrarily high spectral efficiencies can be achieved with QAM by setting a suitable constellation size, limited only by the noise level and linearity of the communications channel [17] [18].

The probability of error for a Rectangular QAM-

$$P_{bc} = \frac{4}{k} \left(1 - \frac{1}{\sqrt{M}} \right) Q \left(\sqrt{\frac{3k E_b}{M-1 N_0}} \right) \quad (9)$$

The probability of error for a Rectangular QAM-

$$P_s = (M-1) Q \left(\sqrt{\frac{d_{min}^2}{2N_0}} \right) \quad (10)$$

D. M-PSK

A PSK could be constructed with any number of phases. When more than 8 phases, the error-rate becomes too high and there

are better, though more complex, modulations available such as quadrature amplitude modulation (QAM) [19].

The probability of error-

$$P_s \approx 2Q \left(\sqrt{2\gamma_s} \sin \frac{\pi}{M} \right) \quad (11)$$

$$P_s \approx \frac{1}{k} P_s \quad (12)$$

E. Differential Phase Shift Keying (DPSK)

Differential phase shift keying (DPSK) is a common form of phase modulation that conveys data by changing the phase of the carrier wave. The problem of the rotation of the constellation due to some effect is overcome by using the data to change rather than set the phase. In differentially encoded QPSK (DQPSK), the phase-shifts are 0°, 90°, 180°, -90° corresponding to data '00', '01', '11', '10'. This kind of encoding may be demodulated in the same way as for non-differential PSK but the phase ambiguities can be ignored. Thus, each received symbol is demodulated to one of the points in the constellation and a comparator then computes the difference in phase between this received signal and the preceding one [20]. The difference encodes the data as described above.

The probability of error-

$$P_b = \frac{1}{2} e^{-E_b/N_0} \quad (13)$$

IV. MIMO-OFDM

A. OFDM (Orthogonal Frequency Division Multiplexing)

The main idea of OFDM is to divide a channel into N sub-channels, one carrier on each sub-channel, called a subcarrier, and each subcarrier is orthogonal to each other.

The basic block diagram of an OFDM system is shown in Fig. 2.

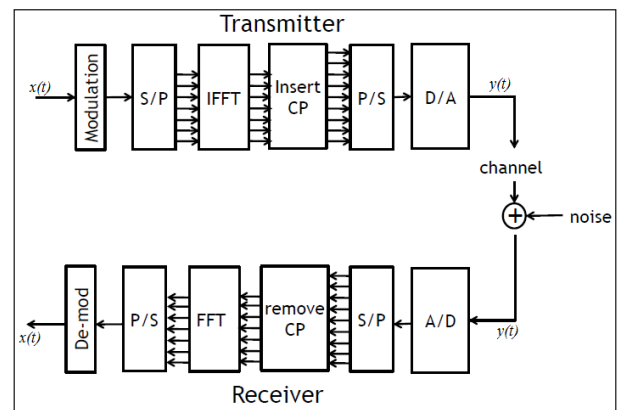

Fig. 2: Basic Block Diagram of an OFDM System

In implementation, a high-speed serial input data signal stream is converted into N parallel low-speed sub-data streams, and modulated onto each sub-carrier for transmission. After serial/parallel conversion, N parallel data are simultaneously output and modulated on N subcarriers [16].

The number of N subcarriers can be expressed as-

$$f_n = f_c + \frac{n}{T_s} \quad (14)$$

Then an OFDM signal at the m^{th} moment can be expressed as-

$$S_m(t) = \text{Re} \left\{ \sum_{n=0}^{N-1} d(n) e^{j2\pi f_n t} \right\}, 0 < t < T \quad (15)$$

Since, OFDM is emitted after the serial-parallel conversion of N symbols, the symbol rate is the original OFDM symbol rate $1/N$, so we can write $T_s = NT_s$.

When the guard interval between OFDM symbols is not considered, we can write-

$$\begin{aligned} S_m(t) &= \text{Re} \left\{ \sum_{n=0}^{N-1} d(n) e^{j2\pi f_n t} \right\} \\ &= \text{Re} \left\{ \sum_{n=0}^{N-1} d(n) e^{j2\pi \frac{n}{NT_s} t} e^{j2\pi f_c t} \right\} \\ &= \text{Re} \{ X(t) e^{j2\pi f_c t} \} \end{aligned} \quad (16)$$

Where

$$X(t) = \sum_{n=0}^{N-1} d(n) e^{j2\pi \frac{n}{NT_s} t}$$

And $X(t)$ complex equivalent baseband of the transmitted signal.

Sampling $X(t)$ with a sampling rate of $1/T_s$, then when $k = kT_s$, the sampled value satisfies

$$X(k) = X(kT_s) = \sum_{n=0}^{N-1} d(n) e^{j2\pi \frac{n}{NT_s} kT_s} \quad (17)$$

$X(k)$ is exactly the result of the N -point inverse discrete Fourier transform (IDFT) of $d(n)$. In practical applications, we can use the IFFT operation to complete the subcarrier modulation process of the OFDM complex equivalent baseband signal, and complete the demodulation process with Fast Fourier Transform (FFT) [16].

B. MIMO (Multiple Input and Multiple Output)

MIMO system refers to the data transmission scheme which contains multiple antennas at both transmitter and receiver end. This system is also known as transmit and receive diversity. The

MIMO system provides higher capacity, spectral efficiency and higher data transmission rates than any other data transmission scheme. This system is more reliable due to its multipath in the transmitter to the receiver. Although in MIMO system processing is required at both transmitter and receiver, it will provide channel robustness and data throughput capacity [21] [22] [23].

Consider a MIMO system with N_T transmit and N_R receive antennas as illustrated in Fig. 3. For getting transmit and receive signal in the both sides indiscriminately, let the antennas be omnidirectional.

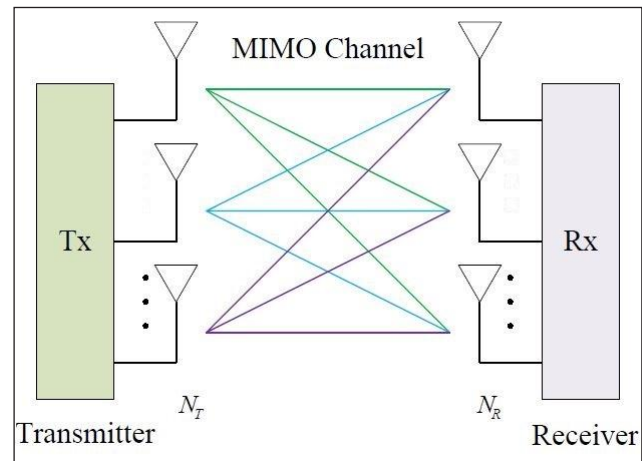

Fig. 3: $N_T \times N_R$ MIMO System Model

In the MIMO system, the linear link model between the transmit and receive antennas can be represented in the following vector notation as-

$$y = Hx + n \quad (18)$$

Where y is the $N_R \times 1$ receive signal vector and x is the $N_T \times 1$ transmitted signal vector, n is the $N_R \times 1$ complex Gaussian noise vector and H is the $N_R \times N_T$ normalized channel matrix which can be represented as-

$$H = \begin{pmatrix} h_{11} & h_{12} & \dots & h_{1N_T} \\ h_{21} & h_{22} & \dots & h_{2N_T} \\ \vdots & \vdots & \dots & \vdots \\ h_{N_R1} & h_{N_R2} & \dots & h_{N_RN_T} \end{pmatrix} \quad (19)$$

Each element h_{mn} represents the complex gain between n^{th} transmit and m^{th} receive antennas.

For the number of N_T and N_R in transmit T_X and receive R_X antennas respectively, the capacity of the MIMO system is expressed as-

$$C_{MIMO} = \left[\det \left(I + \frac{\rho}{N_T} H H^\dagger \right) \right] \frac{\text{bps}}{\text{Hz}} \quad (20)$$

Where $\det(\cdot)$ denotes the determinant of a matrix, I is an $N_R \times N_T$ identity matrix, ρ is the average received Signal to Noise Ratio (SNR) and H^\dagger is the complex conjugate transpose of H .

V. PROPOSED WORK

The implemented work includes MIMO-OFDM as well as a comparative analysis of different modulation techniques according to various wireless communication channels. The MIMO-OFDM systems is the combination of MIMO systems and OFDM systems. The MIMO-OFDM systems that we have been implemented is shown in Fig. 4 and the required parameters for MIMO-OFDM is listed in the Table I.

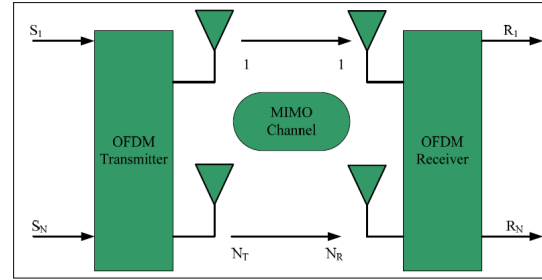

Fig. 4: MIMO-OFDM System

TABLE I: IMPLEMENTED PARAMETERS FOR MIMO-OFDM SYSTEM

Properties	Values
FFT Length	64
Number of Guard Band Carriers	[6 ; 5]
InsertDCNull	True
PilotInputPort	True
CyclicPrefixLength	16
Windowing	False
Number Symbols	1
No. of TransmitAntennas	2

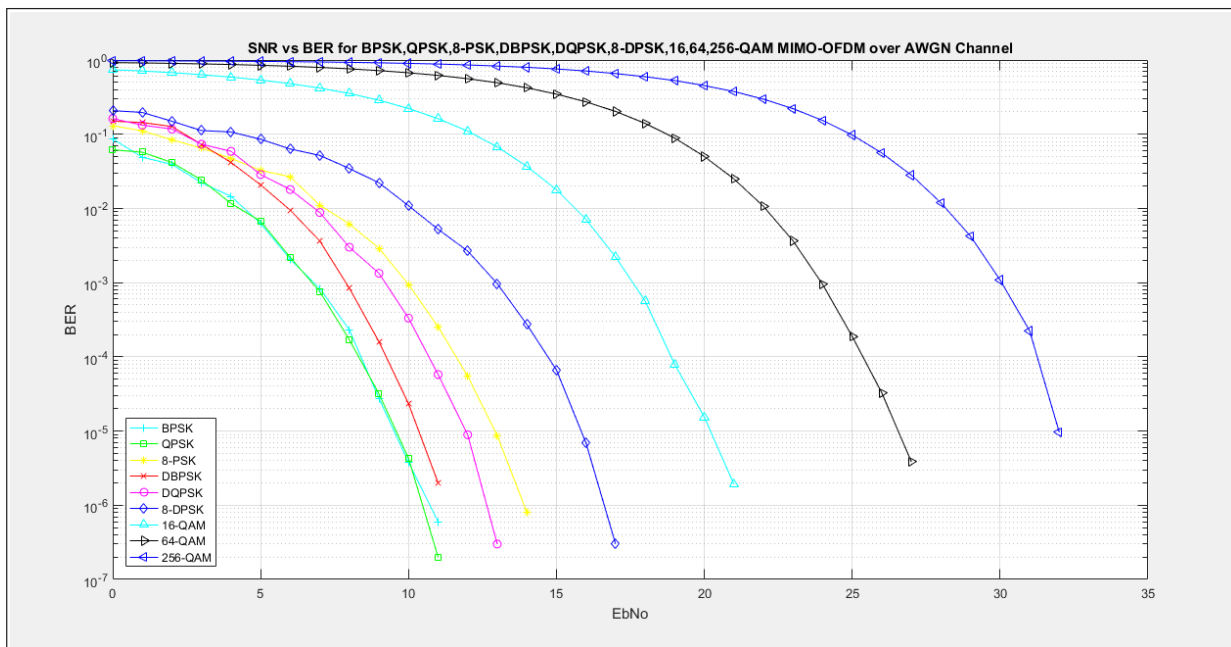

Fig. 5: Performance of MIMO-OFDM in AWGN Channel

VI. SIMULATION RESULTS AND DISCUSSION

A. Comparison in AWGN

During apply the different modulation techniques to the AWGN channel under the MIMO-OFDM system we measured the

efficiency of the system. The Fig. 5 shows performance curve of the simulation results for various modulation techniques under the AWGN channel. We have plotted the performance curve based on the Bit Error Rate and Signal to Noise Ratio value. We considered the system efficiency under the low Signal to Noise Ratio value with the minimum Bit Error Rate. From the figure it is shown that at any instant value of Signal to Noise

Ratio (e.g. 10 dB) we have got the minimum Bit Error Rate for QPSK and maximum Bit Error Rate for 256-QAM modulation technique. For the same procedure for other modulation

techniques we will get more clear idea on the system efficiency and select the best techniques based on our requirements.

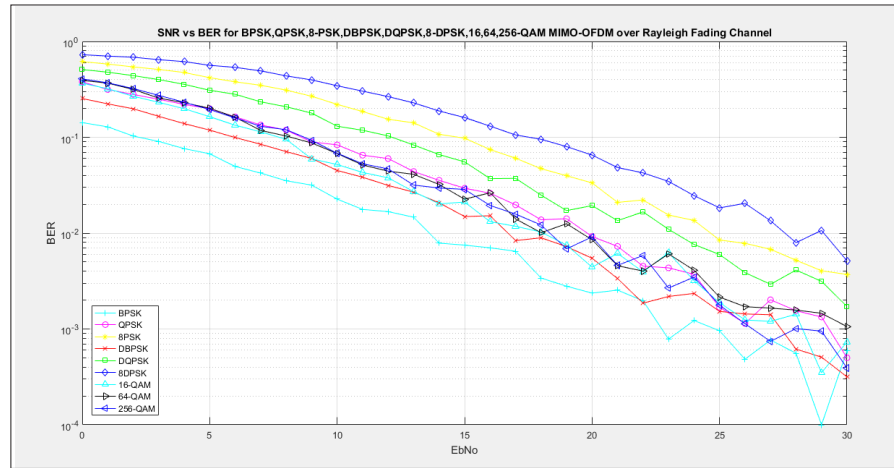

Fig. 6: Performance of MIMO-OFDM in Rayleigh Channel

B. Comparison in Rayleigh Fading Channel

The similar procedure is applied to Rayleigh Channel retaining the same conditions. The efficiency which is obtained based on the simulation result (i.e.) Bit Error Rate vs Signal to Noise ratio aids in showing the most suitable modulation scheme based on the users requirement. The plot shows that the Bit Error Rate is minimum for BPSK and is maximum for 8 DPSK when plotted against SNR (e.g. 10 dB). This result proves that the modulation efficiency varies with the channel as the result varies when compared to that of the AWGN channel.

C. Comparison in Rician Fading Channel

The below simulated output proves that the efficiency of BPSK is higher when compared to the other considered modulation schemes under a Rayleigh fading channel. In the accounted modulation techniques for this channel the efficiency is observed to be lowest for the 8 DPSK. Hence, in order to accompany users with spectral efficiency and accuracy BPSK proves to be an optimum technique when compared to the other modulation schemes in this paper.

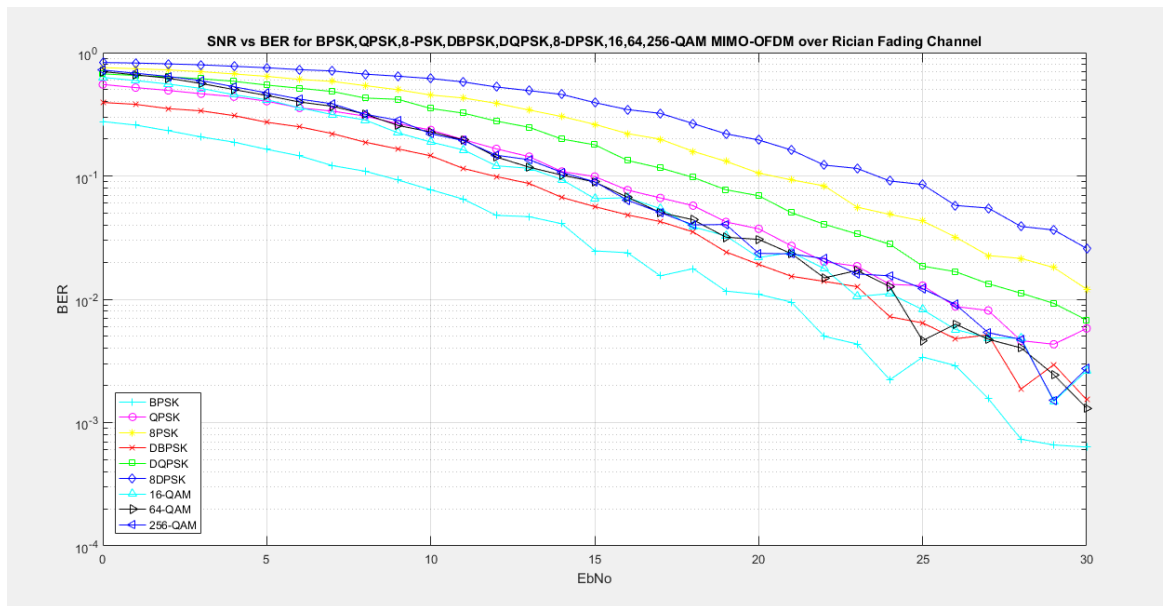

Fig. 7: Performance of MIMO-OFDM in Rician Channel

VII. CONCLUSION

This paper has attempted to present about the appropriate information of Multiple Input Multiple Output-Orthogonal Frequency Division Multiplexing (MIMO-OFDM) system and also discussed about different modulation techniques which are popularly used in MIMO-OFDM systems. In this paper, we have proposed a work based on the MIMO-OFDM system with some parameters as well as a comparative analysis has been accomplished by analyzing the performance of that MIMO-OFDM system for different modulation techniques where we have used BPSK, QPSK, M-PSK, D-BPSK, D-QPSK, DPSK and QAM modulation techniques. By analyzing the performances of MIMO-OFDM system from the performance curve, we have concluded that the QPSK modulation is best suited for AWGN channel and BPSK modulation is best suited for fading channel like Rayleigh and Rician fading channel.

ACKNOWLEDGMENT

We would like to cordially thank all the teachers of the department of Computer Science and Engineering, Islamic University-Bangladesh and most importantly our beloved parents for their continuous support.

CONFLICT OF INTERESTS

The authors declared that there are not any conflicts of interest concerning with this paper works.

REFERENCES

- [1] T. Rappaport, *Wireless Communications: Principles and Practice* (2nd ed.). Prentice Hall PTR, USA, 2001.
- [2] D. Tse, and P. Viswanath, *Fundamentals of Wireless Communication*. Cambridge University Press, USA, 2005.
- [3] R. Prasad, *OFDM for Wireless Communications Systems*. Artech House, Boston, London, 2004.
- [4] F. B. Frederiksen, and R. Prasad, "An overview of OFDM and related techniques towards development of future wireless multimedia communications," *Proceedings RAWCON 2002. 2002 IEEE Radio and Wireless Conference (Cat. No. 02EX573)*, Boston, MA, USA, 2002, pp. 19-22, doi: 10.1109/RAWCON.2002.1030107.
- [5] T. Hwang, C. Yang, G. Wu, S. Li, and G. Y. Li, "OFDM and its wireless applications: A survey," in *IEEE Transactions on Vehicular Technology*, vol. 58, no. 4, pp. 1673-1694, May 2009, doi: 10.1109/TVT.2008.2004555.
- [6] A. Goldsmith, S. A. Jafar, N. Jindal, and S. Vishwanath, "Capacity limits of MIMO channels," in *IEEE Journal on Selected Areas in Communications*, vol. 21, no. 5, pp. 684-702, Jun. 2003, doi: 10.1109/JSAC.2003.810294.
- [7] A. Khan, and R. Vesilo, "A tutorial on SISO and MIMO channel capacities," 2006.
- [8] Y. S. Cho, J. Kim, W. Y. Yang, and C. G. Kang, *MIMO-OFDM Wireless Communication with MATLAB*. Wiley Publishing, 2010.
- [9] M. K. Wali, R. A. Fayadh, and D. Y. Al_tae, "Performance of AWGN and fading channels on wireless communication systems using several techniques," 6, 2018.
- [10] A. A. Giordano, and A. H. Levesque, "Digital communications BER performance in AWGN (BPSK in Fading)," in *Modeling of Digital Communication Systems using SIMULINK*, Wiley, 2015, pp. 119-140, doi: 10.1002/9781119009511.ch6.
- [11] N. T. Awon, Md. A. Islam, Md. M. Rahman, and A. Z. M. Touhidul Islam, "Effect of AWGN & fading (Rayleigh & Rician) channels on BER performance of a WiMAX communication system," *International Journal of Computer Science and Information Security*, vol. 10, no. 8, pp. 11-17, 2012.
- [12] "Techniques," in *Digital Video Broadcasting (DVB)*. Springer, Berlin, Heidelberg. Available: https://doi.org/10.1007/978-3-662-04562-6_7
- [13] G. S. Kishore, and H. Rallapalli, "Performance assessment of M-ary ASK, FSK, PSK, QAM and FQAM in AWGN channel," *2019 International Conference on Communication and Signal Processing (ICCSP)*, Chennai, India, 2019, pp. 0273-0277, doi: 10.1109/ICCSP.2019.8697922.
- [14] A. Babu, and K. Rao, "Evaluation of BER for AWGN, Rayleigh and Rician fading channels under various modulation schemes," *International Journal of Computer Applications*, vol. 26, pp. 23-28, 2011, doi: 10.5120/3132-4317.
- [15] M. M. Madankar, and P. S. Ashtankar, "Performance analysis of BPSK modulation scheme for different channel conditions," *2016 IEEE Students' Conference on Electrical, Electronics and Computer Science (SCEECS)*, Bhopal, 2016, pp. 1-5, doi: 10.1109/SCEECS.2016.7509290.
- [16] B. Hu, and N. C. Beaulieu, "Performance of an ultra-wideband communication system in the presence of narrowband BPSK- and QPSK-modulated OFDM interference," in *IEEE Transactions on Communications*, vol. 54, no. 10, pp. 1720-1724, Oct. 2006, doi: 10.1109/TCOMM.2006.881338.

- [17] A. Kansal, L. Kansal, and K. Singh, "Performance analysis of MIMO-OFDM system using QOSTBC code structure for M-QAM," *Canadian Journal on Signal Processing*, vol. 2, pp. 4-15, 2011.
- [18] S. O. Ajose, R. A. Bakare, and A. L. Imoize, "BER comparison of different modulation schemes over AWGN and Rayleigh fading channels for MIMO-OFDM system," *International Journal of Communication Networks and Distributed Systems*, vol. 18, no. 2, p. 129, 2017, doi: 10.1504/IJCND.2017.082102.
- [19] P. Bisht, M. Shukla, and S. Mishra, "M-ARY PSK scheme in cellular environment," *International Journal of Computer Applications*, vol. 99, pp. 20-24, 2014, doi: 10.5120/17426-8279.
- [20] S. E. Mirnia, A. Zarei, S. D. Emami, S. W. Harun, H. Arof, H. Ahmad, and H. M. H. Shalaby, "Proposal and performance evaluation of an efficient RZ-DQPSK modulation scheme in all-optical OFDM transmission systems," in *Journal of Optical Communications and Networking, IEEE/OSA*, vol. 5, no. 9, pp. 932-944, 2013.
- [21] D. Bala, G. M. Waliullah, Mst. A. Hena, Md. I. Abdullah, and Md. A. Hossain, "Study the performance of capacity for SISO, SIMO, MISO and MIMO in wireless communication," *Journal of Network and Information Security*, vol. 8, no. 1-2, pp. 1-6, 2020.
- [22] T. K. Roy, "Capacity and performance analysis of Rayleigh fading MIMO channels using CSI at the transmitter side," *IJAR-CSIT*, vol. 1, no. 3, Jul. 2012.
- [23] G. M. Waliullah, D. Bala, Mst. A. Hena, Md. I. Abdullah, and Md. A. Hossain, "Performance analysis of zero forcing and MMSE equalizer on MIMO system in wireless channel," *Journal of Network and Information Security*, vol. 8, no. 1-2, pp. 19-25, 2020.